

QSL SWAPPERS: AWARDS + 250 NEW LISTINGS

JULY 1963

50c

S9

the citizens band journal

How the FCC Monitors CB



EXCLUSIVE!

NEW FROM INTERNATIONAL.

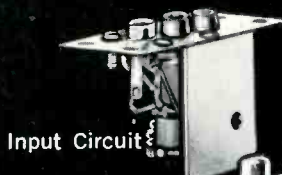

Nuvistor/Cascode
Preamplifier

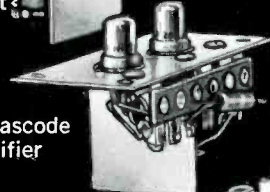

Innerstage
Coupling Coil

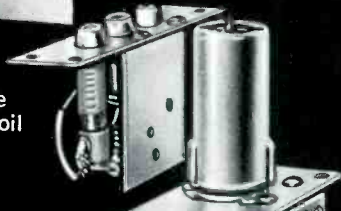

Mixer

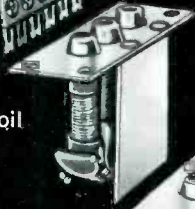

IF Output Coil

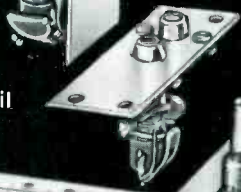

Oscillator Tuning Coil

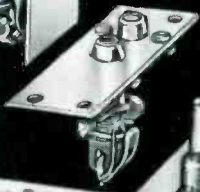

Oscillator

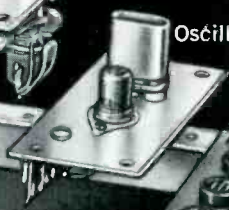

Power
Connectors

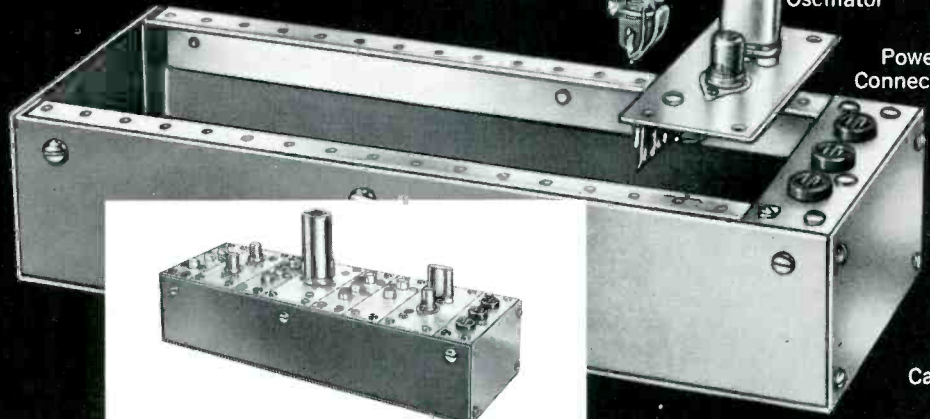

Case

**AN EXCITING
NEW APPROACH
TO DESIGN AND
CONSTRUCTION
...AM-FM
-SSB
-DSB**

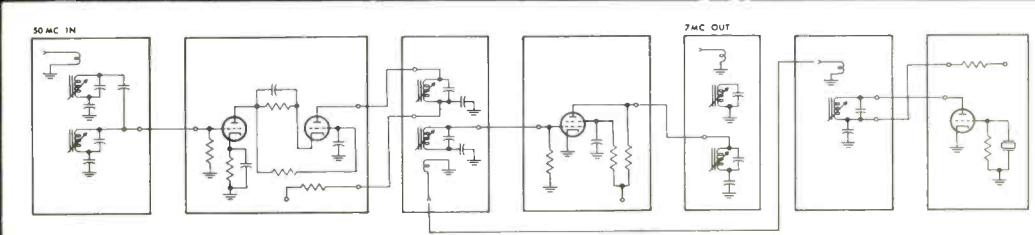
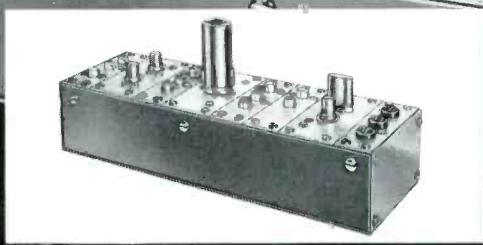

A O C *

* Add - On - Circuits

Amateurs and experimenters will discover a new and easier way to build a wide variety of communication and electronic gear with International **AOC** units . . . individually wired oscillators, preamplifiers, detectors, etc., each tested and mounted on miniature metal chassis.

For example, the eight **AOC** units (illustrated) have been assembled to make a 6 meter converter. Each circuit may be removed to make modifications, or build other equipment. Simple to build, and so easy to change.

AOC units permit custom building for a wide range of frequencies, modes, and power. RF coils are available from 200 kc to 450 mc. IF transformers are available from 262 kc to 10.7 mc. Transmitter power to 100 watts. Matching cases, complete with hardware, available in a variety of lengths.

If you are planning to build a receiver, transmitter, converter, or other electronic equipment use International **AOC** units.

PREAMPLIFIERS • MIXERS • OSCILLATORS • INTERMEDIATE FREQUENCY AMPLIFIERS • DETECTORS • DISCRIMINATORS • BUFFERS • POWER AMPLIFIERS • MODULATORS • FREQUENCY MULTIPLIERS • SPEECH AMPLIFIERS • RECTIFIERS • FILTERS • REGULATORS • POWER TRANSFORMERS • OSCILLATOR BRIDGES •

AOC units are moderately priced from.....\$2.00 up.

INTERNATIONAL ANTENNAS FOR 6 METERS

BASE STATION VERTICAL

This antenna offers exceptional improvement of signal to noise ratio. Shunt fed, grounded radiator. Rigid aluminum and cadmium plated steel construction. Vertical length adjustable. Cat. No. 160-129 \$27.95



MOBILE

Base loaded whip antenna for installation on roof of auto. May be mounted on trunk lid or door facing with International blind mounting bracket (Cat. No. 160-126) Sealed loading coil-adjustable whip. Cat No. 160-130 \$19.95



For complete details, mail coupon today.



International Crystal Mfg. Co., Inc.
18 North Lee
Oklahoma City, Oklahoma
Please rush details on AOC units.

Name _____

Address _____

City _____ Zone _____ State _____

18 NORTH LEE • OKLAHOMA CITY, OKLAHOMA



the citizens band journal

Vol. 3, No. 1

July, 1963

S. R. COWAN, PUBLISHER

300 West 43rd Street New York 36, N. Y.

FEATURES

FCC Announces New CB License Fees	Tom Kneitel, KBG4303	7
As mentioned last month in S9.		
The FCC Is Listening to You!	Lee Aurick, 2W2870	9
S9 visits an FCC monitoring station.		
Read That Schematic!	Jim Gibson, 2W7610	12
Most requested article.		
Watts the Output?	Basil Barbee, 9W0831	16
An ultra-simple CB output meter.		
Audio-Ability with Dynamic Mikes	Jim Kyle, KEG3382	18
Kyle really takes a deep look at them.		
Transmission Lines	Don Stoner, 11W1507	31
Don adds his comments on this important topic.		
QSL Card Swappers' Awards Announced		35
Along with about 250 new swappers listed!		
Shortened Antennas & Their Tuning	Ed Noll, KCC2618	39
The Master makes it a short story.		
Helpful CB Books	Herb Friedman, 2W6045	44
Want to know what to stock up on?		

DEPARTMENTS

Reader Mail	4
KBG4303 Rides Again/Tom Kneitel, KBG4303	7
Part 15 Korner/Dean Detton, N-17	37
On The Counters	22
Antennas/Ed Noll, KCC2618	39
Test Gear/Herb Friedman, 2W6045	44
CB Answerman/Len Buckwalter, KBA4480	42
Card Swappers Unlimited	34
CB Chit Chat /John Krejc, 2W4586	45
Washington Outlook/Ed Frederick, 2W4580	49

STAFF

editor **Tom Kneitel, KBG4303**

contributing editor **Lee Aurick, 2W2870**
contributing editor **Ed Noll, KCC2618**
contributing editor **Edwin Frederick, 2W4580**
contributing editor **Paul Arnovitz, XM52127**
contributing editor **John Krejc, 2W4586**
editorial asst. **Lilia Neira**
advertising representative **Dick Cowan**
advertising representative **Jack Schneider, 2W5669**
circulation manager **Hal Weisner, KBG4528**
production manager **Cary L. Cowan, KBG4036**
edit. production **Sol Nussbaum, KBG4903**
publication consultant **David Saltman**

S9 (title registered U.S. Post Office) is published monthly by Cowan Publishing Corp. Executive, editorial and advertising offices at 300 West 43rd Street, New York 36, N. Y. Telephone JU 2-4460.

Subscription Rates: One year \$5.00, two years \$9.00, three years \$13.00 in United States and Possessions, APO, FPO, and Canada.

Printed in U.S.A. Entire contents copyright 1963 by Cowan Publishing Corp. S9 does not assume responsibility for unsolicited manuscripts. We regard all material sent to us in CB club publications as being intended for publication in S9 as a public relations gesture of the club. We cannot pay for the use of this public relations material, although we do pay for editorial material which is specifically written for us and accepted for publication.

Controlled Circulation Postage Paid at New York, N. Y.

POSTMASTER: SEND FORM 3579 TO: S9, 300 WEST 43RD STREET, NEW YORK 36, N. Y.

FEATURE FOR FEATURE — DOLLAR FOR DOLLAR YOUR BEST BUY IN CB RADIO

THE NEW RCA MARK VIII

27-Mc CITIZENS BAND 2-WAY RADIOPHONE

UP TO 9 FIXED, CRYSTAL-CONTROLLED TRANSMIT-AND-RECEIVE CHANNELS. PLUS ALL-CHANNEL TUNABLE RECEIVER.

CONVENIENT ACCESS TO CRYSTALS FOR QUICK CHANGING

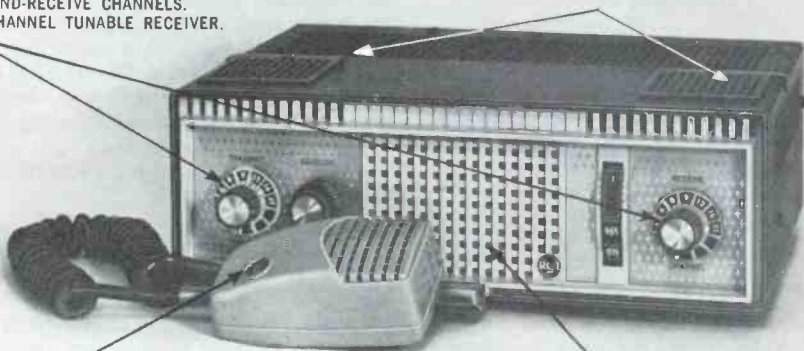

PUSH-TO-TALK CERAMIC MICROPHONE with coiled cord.

EXCELLENT VOICE REPRODUCTION—high intelligibility.

EXCELLENT TRANSMITTER MODULATION CHARACTERISTICS

IMPROVED AUTOMATIC NOISE LIMITER reduces effects of ignition and similar interference.

COMPACT AND LIGHTWEIGHT 3½" high, 9 pounds. Fits easily under any auto dashboard.

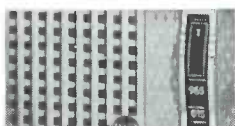

Continuously tunable receiver picks up any of the 23 C-B channels. Tunes either by channel number or frequency.



Illuminated working channel. Pilot lamps behind the fixed-channel dials show the channels being worked.



Separate mobile power supply. (Optional) 6- or 12-volt, for car or boat. All units contain AC power supply.



Channel-marker kit. Select channels best for your area, then mark them with the self-adhering labels included.

ONLY \$149.50*

*OPTIONAL LIST PRICE

Get all the Facts Before You Buy.
Mail Coupon Today. Paste on 4¢ Post-Card.

RCA ELECTRON TUBE DIVISION
Commercial Engineering Dept. G-132-R
415 South Fifth Street, Harrison, N. J.

Please send more information on the RCA Mark VIII C-B Radiophone

Name _____

Address _____

City _____ Zone _____ State _____



The Most Trusted Name
in Electronics

Write to our advertisers for special product news

July 1963 • S9 • 3

READER MAIL

BEING CLUBBED

Editor:

I would like some information on the so-called American Citizens Band Association (ACBA). I believe that the organization is not really up to par and is just an attempt to get Ernest L. Walker, ex-15W1670, back on the air. He had his license revoked by the FCC. This club, in my opinion, will or could do great harm to future CB'ers. I am enclosing some literature which the organization sent me. Thanks for a good job with S9. From a CB old timer.

Bob Charbonneau, 18W4062
Kankakee, Ill.

Bob, your letter was but one of a flood from irate CB'ers who swamped our offices with violent complaints about this preposterous anti-FCC "club." Details of the organization were outlined last month in our June editorial. We suggest that readers ignore the barrage of hate-the-FCC literature and requests for funds turned out in reams by this small extremist group.

HAPPY, HAPPY, HAPPY!

Tom:

KBG4303 Rides Again, and again, and again! Yours is the only editorial read every issue, every month—FIRST!

Rich Blomberg, KHA9138/CENT. 26
Chicago, Ill.

Editor,

I am the Secretary of the Lake Placid 5 Watters Club. The President of the club and I wish to voice a complaint! There aren't enough copies of S9 on the local newsstands. As a result, we are in a constant battle to convert the club's "borrowers" into regular subscribers. We can't say "no" to the loan of S9 to fellow members, but have a heart and send some more issues up our way each month! The password around here is, "Get your own S9!"

Francis Sheffield, KID0555
Lake Placid, N. Y.

Gentlemen:

We here in Shreveport want you to know that your magazine easily reads "30 over S9," a real fine signal here in the deep south. Our club, the Caddo-Bossier CB Radio Club, has subscribed en masse to S9 and this is a note to let you know that there hasn't been even one single complaint so far. We really like it, even if it's run by a bunch of Yankees! But I suppose everyone can't live here in the south.

J. H. Ellington, Sec.-Treas.
Caddo-Bossier CB Radio Club
Shreveport, La.

A MODEL COMMENT

Editor:

I think you are a louse. First, for even suggesting that Part 15 handy talkies share the Class C radio control frequencies and second, for your survey which determined that certain Class C frequencies were seldom used. I do not read your rag but if no one has ever told you, radio control by its very nature requires a minimum amount of interference and other modes of transmission cannot be tolerated. An expenditure of over \$700 in model aircraft can be shot down by some damn fool whistling or yakking on a handy talkie. Since you run a magazine primarily in the interests of Class D I would think you would put your own house in order before going on a witch hunt to your neighbors. You may rate an S9 with Class D readers but right now you're a poor S1 with Class C people until you straighten out and fly right. Print this along with your change of heart.

Joseph Mackora, Jr., 1W5371 (Class C)
328 Saybrooke St.
Hartford, Conn.

Actually, we have received quite a bit of mail from radio control model enthusiasts, this particular one was a little more violent than most. Part 15 stations operate on Class C frequencies with full FCC authority, none has ever been known to cause interference to radio control operations. Part 15 hobbyists might like to drop Mr. Mackora a card or letter and let him know that they are not "damn fools."

CALL AREA MAPS

Tom,

We are interested in purchasing about one dozen of the brand new 1964 CB call area maps which S9 is issuing. Please let us know where we can get these.

Flaherty's 2-Way Radio
Bend, Oregon

These maps are being quickly gobbled up by individual CB'ers and for resale by CB shops. They are available for 25¢ each or at special bulk rates for stores wishing to re-sell them. Order yours from the S9 offices now.

TRAVELERS

Editor:

While traveling cross-country this month I was stalled and stranded in a sand storm near Palm Springs, Calif. My call of distress was quickly answered by 11Q5345 of San Bernardino (then mobile). He told me that he was an S9 Area Public Relations Editor. His services certainly speak well of his organization. Thanks for 11Q5345 and S9. Lt. A. E. Weselesky, KID1237
Naval Post Graduate School
Monterey, Calif.

hallicrafters gives you the basic superior performance you need for just \$159.95...

All the gadgets ever invented wouldn't improve the tremendous basic performance and reliability of the CB-3A. You get 8-channel, crystal controlled convenience . . . 100% modulation capability . . . 40 db. min. adjacent channel rejection . . . less than 1 μ v. sensitivity . . . 3 kc. selectivity . . . removable accessory panels and built-in accessory jack—plus a reliability record unequalled in the field.



CB-3A

eight-channel, dual conversion
basic transmitter/receiver

...and lets you decide which extras you want

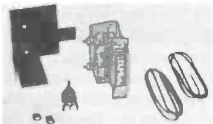

HA-9 S-Meter Kit. Illuminated. Complete hardware; installs in minutes in removable CB-3A front panel. Universal. \$8.95.

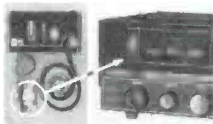

HA-11 Noise Eliminator. "Rocket Buster" deluxe. Mounts completely hidden on back of CB-3A; front panel thumb control. \$15.95.



HA-3 Noise Suppression Kit. Pass condensers, ground braid, etc. Minimize electrical system noise. \$13.48. SP-3 spark plug suppressor, \$2.95.



HA-12 Encoder/Decoder. Full duplex selective calling system. No tubes or transistors. Single switch operation. \$79.95. HA-12A Encoder only, \$44.95.

the new ideas in communications
are born at . . .

hallicrafters

5th and Kostner Avenues • Chicago 24, Illinois

Overseas Sales: International Division, Hallicrafters • Canada: Gould Sales Co., Montreal, P.Q.



HEATHKIT CITIZEN'S BAND

world's biggest line
of top quality
2-way radio values



MARINE CB

Styled to match Heathkit Marine equipment • 5 transmit-receive channels • All-channel tuning • RF stage for extra sensitivity • Crystal filter for extra selectivity • Efficient transmitter for extra range • 3-way power supply • Kit MW-33, \$89.95



DELUXE MASTER STATION

5 transmit-receive channels • All-channel tuning • 4-tone selective calling • Tuning meter • Squelch • Noise limiter • 3-way power supply • Kit GW-42, \$119.95



SINGLE CHANNEL

One transmit-receive channel • Sensitive superhet. receiver • Squelch • Noise Limiter • AC power supply plus accessory DC supply • Kit GW-12A, \$39.95

ACCESSORIES

Heathkit offers a complete line of CB accessories including selective-call kits, mobile and fixed station antennas, microphones, and extra crystals.

Walkie Talkies



GW-52-1 WATT
10-transistor, 2-diode circuit; 1/2 uv sensitivity; built-in charger; \$20 rechargeable battery included. Pair \$139.95; Each \$74.95



GW-30-100 MILLIWATTS
4-transistor circuit; 4 uv sensitivity; 9-v. battery lasts to 75 hours. Pair \$35; Each \$19.95



GW-21-100 MILLIWATTS
9-transistor, 2-diode circuit; 1 uv sensitivity; 9-v. battery lasts to 75 hours. Pair \$84.95; Each \$44.95

Heathkit, pioneer name in citizen's band radio . . . the name found wherever fast-moving, dependable 2-way radio communications are functioning . . . the name associated with quality at great savings. Whether you use citizen's band radio for your work or recreation, there is a Heathkit CB model to fit your purpose and budget. Five different 5-watt basic transmitter models are available with various power supply options. Three different walkie-talkie units are ready to keep you "in touch" . . . each in a different power and price class. And all Heathkit CB equipment is available as do-it-yourself kits or factory-assembled and tested . . . either way, you save more, get more for your money with a Heathkit. See the Heathkit Catalog for full details on the very model you need to put you "on the air."



HEATH COMPANY / Benton Harbor 43, Michigan

Please send my free 1963 Heathkit catalog

Name _____

Street _____

City _____ Zone _____ State _____

Prices and specifications subject to change without notice. Dealer & Export prices slightly higher.



FREE 1963
HEATHKIT CATALOG
Over 250 money-saving, do-it-yourself kits for stereo/hi-fi, citizen's band, amateur radio, marine, test & lab, educational, electronic organs, television, and more. Save up to 50% on your electronic equipment needs with Heathkit. Send for your free Heathkit catalog today!

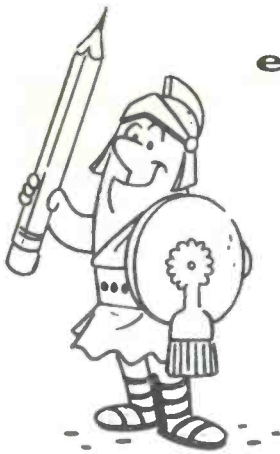

editorial

KBG4303 rides again!

by TOM KNEITEL
EDITOR, S9

LICENSE FEES ANNOUNCED

If you read every nook and cranny of S9, you may have noticed at the end of last month's "Washington Outlook" column we had a small blurb about possible FCC license fees of \$5 to \$10 for CB'ers within the next 6 months. As usual, S9 called the shots ahead of the official release from the FCC, however the release came through anyway.

This license-fee plan has now been trotted out for what appears to be its final time—having made its initial appearance in Docket 10869 of January 28, 1954. This proposal failed and several subsequent tries at pushing it over the hill also resulted in zero results.

Under the new Docket, which goes into effect on January 1, 1964, CB'ers will donate \$8 to Uncle Sam for their CB licenses, and \$8 for all renewals and modifications of the license. Ham operators, on the other hand, will spend \$4 for filing the original application and renewals and \$2 for modifications. Novice class licenses remain free. Broadcasting stations will be shelling out \$50 for AM and FM licenses and \$100 for TV licenses. Other services also got hit by the fees with the exception of certain public service licensees (police, fire, etc.).

Looking over the new resolution, Docket 14507, which came into being even after two of the seven FCC Commissioners refused to ratify it, several thoughts come into the picture which relate to its effect on CB and CB'ers. We think that you might like to mull them over with us.

In view of some of the wording used, we feel that the fees are most discriminatory against the Citizens Radio Service. For instance, the Commission, in establishing the \$2 fee for a restricted radiotelephone permit,

stated, "If this amount were reduced our objective to limit such licenses to persons having an actual need therefore would not be accomplished." In our opinion, the \$8 fee for CB licenses was imposed as a regulatory measure to thus strangle off the growth of the CB service with the Commission arbitrarily deciding that having the \$8 fee will put you in the status of "having a need for the service."

We feel that it is discriminatory in the respect that 50,000 watt commercial broadcasting stations, who are in radio for profit, will be spending \$50 while we are paying almost 20% of this price to be able to use a CB rig. It is interesting to note, by the way, that in the original 1954 proposal, broadcasting stations were going to be hooked for \$325 with Hams in line for a \$3 fee. The broadcasting station fee dropped 85%, the Ham fee went up 33%. Commissioner Robert Bartley, who refused to vote along with the 5 Commissioners who passed this Docket, stated that he believes broadcasting stations should be charged fees more equitably determined by relation to their advertising card rate than by the imposition of the flat fees as being done in Docket 14507.

Carrying this thought along further, it would seem more equitable if CB licenses were charged on the basis that we are not using the service for a profit, and the only monies involved are those which are saved by commercial enterprises using the service to expedite deliveries, etc.

On the other hand, if the CB charges are based upon the fact that a certain amount of personnel time is spent processing CB applications, why are we being forced to pay out \$8 while Hams, whose applications re-

Continued on page 50

BROWNING CB EQUIPMENT NOW AVAILABLE AT MORE THAN 100 FRANCHISED SERVICE CENTERS



ACROSS THE NATION

Browning Service Centers are operated by conscientious people who have a sincere interest in Citizens Band Radio. They are at your service to provide you with spare parts, repairs and Browning equipment sales. We invite you to visit your Browning Service Center soon and see the complete line of CB base station and mobile equipment on display. *Please write us for the name of the one nearest you.* If there is no Service Center in your area, we will be happy to fill your requests direct from the factory. Remember: Investigate before you invest. It will pay you to learn all the facts about Browning before you buy any CB radio equipment!

Don't settle for anything but the best . . . insist on BROWNING, now manufacturing the nation's most complete line of CB transmitters and receivers!



New Browning Drake M-523

all-channel CB mobile transceiver.

Actual Size: 8" x 9" x 3" small

Mail Coupon Today



LABORATORIES, INC.
LACONIA, NEW HAMPSHIRE

Browning Laboratories, Inc., Dept. S9
100 Union Ave., Laconia, N.H.
WITHOUT OBLIGATION, PLEASE SEND:

- Name of nearest Service Center.
- 16-page color CB catalog.
- Information on how to become a Browning Service Center operator.

NAME _____
ADDRESS _____
CITY _____ ZONE _____ STATE _____
CALL LETTERS _____

THE FCC

IS LISTENING

TO YOU!

SPECIAL
REPORT

S9 VISITS AN FCC MONITORING STATION

by LEE AURICK, 2W2870

S9 EDITORIAL STAFF



Picturesque former farmhouse serves as FCC Laurel, Maryland monitoring facility. Tree in foreground, one of the oldest in State, reputed to be more than 400 years old.

The cordial invitation from Mr. George S. Turner, Chief, Field Engineering Bureau, to visit the FCC's Laurel (Maryland) Monitoring Station held for me the same pleasant anticipation that one might experience at an invitation to Fort Knox. Except—the operation of a monitoring station in operation was certain to be more interesting than a pile of gold bars.

Most people, even licensed radio operators, have little occasion to come in contact with the Commission's Field Engineering Bureau, and after nearly two decades of holding various radio licenses, your reporter was no exception.

Upon receiving the invitation, arrangements for a specific date were made with Mr. Turner, who also offered detailed directions and advised that Mr. Irv Weston, Chief, Monitoring Systems Division, would be on hand to meet me.

The directions through Maryland's beautiful countryside were thorough—and vitally necessary. The FCC makes a point of selecting out-of-the-way sites for their monitoring stations, and doubtless, many of the local residents are completely unaware of the nature of the 237 acre government reservation just a few miles away.

As your reporter turned off the side road on to the reservation, a group of buildings on the left came into view. This would be the FCC Laboratory buildings of which Mr. Turner spoke. Continuing down the lane, the next building that came into view was a very charming colonial farmhouse. This building, set approximately one-half mile off the road, I later learned, is more than two-hundred years old, and houses the monitoring facilities.

Mr. Weston, and Mr. Hobart Johnson, Engineer-in-charge, greeted me, and welcomed me to the station.

After a few minutes spent discussing the purpose for which I had come, to tell S9 readers how a monitoring station operates, I suggested that perhaps I would have a better idea as to the questions I should ask after a tour of the station.

With that, Mr. Johnson led the way into the main monitoring room.

Hundreds of dials and knobs stood-out on the brightly illuminated console. The room was spotless, and our presence almost seemed to intrude on the quiet efficiency of the entire installation.

The teletype machines behind us sprang to life and began their robot-like clatter of dat-dat-dat-dat-. The operator on duty moved

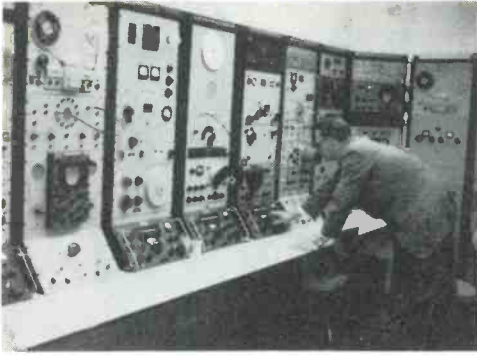

Mr. Johnson adjusts one of the many receivers used for monitoring.

over to read the messages coming in from other monitoring stations.

It was a moment or two before I was able to pull my eyes from the maze of equipment and recall that I was here to ask questions, and not just gape at the gear.

My hosts explained that there are three separate monitoring positions, with back-up equipment and auxiliary facilities for each. The range of frequencies which the station can monitor covers 14 kilocycles to 3,500 megacycles—virtually all of the radio spectrum presently useable for communications. This operation is maintained on a 24 hour basis.

The scope of a monitoring station and its responsibilities include, but are not limited to: rule enforcement; interference investigations; taking radio-location bearings on ships and aircraft in distress; and other activities involving the safety of life and property.

Contrary to the opinion that many Citizen Banders may hold, a very small part of the time at any one monitoring station is devoted to listening to, or "looking at", CB stations.

Laurel is one of the eighteen stations maintained by the Field Engineering Bureau, and all are directly connected by teletype for instant coordination in monitoring activities. Thus each monitoring station, operating on a previously assigned schedule, is able to request assistance from any or all of the other stations, if necessary. Each month one station will set aside other duties to perform specific monitoring projects.

Mr. Johnson demonstrated the ease and rapidity with which it is possible to obtain a bearing as to the direction of any station

they can hear. As I looked into the 'scope, the radar-like device drew a pattern of lines that pointed both at the received station, and 180 degrees in the opposite direction. Only one additional bearing from another monitoring station is required to "fix" the general area of the station being received. This technique is known as triangulation, and once the approximate area has been determined by this method, a mobile-equipped truck is available for close-in pinpointing of the desired station. Three trucks are maintained at this station for monitoring investigations at frequencies up through the UHF-TV channels—nearly 1000 megacycles. Two additional trucks serve to cover other higher microwave frequencies.

My interest in radio locating brought on a discussion of antennas and the various types employed. Mr. Johnson suggested that we step outside to have a look at those that were nearby. Four separate and distinct types of direction-finding antennas were visible in the fields adjacent to the station. Some of them looked like lonely sentinels standing duty at a forgotten outpost, while one particularly large antenna reminded me of a laboratory test-tube centerfuge at rest. I recalled that just a few minutes before, this particular giant, resembling a letter "H", with each vertical element about the size of a CB vertical, had been rotating about thirty revolutions a minute, to trace the pattern I had been watching inside the building.

As if this weren't enough, six huge double rhombics, capable of being terminated at either end by remote switches, dominate most of the reservation. A wide assortment of TV antennas, at least one log-periodic, and a host of other antennas of every description are to be seen in every direction.

Returning inside, Mr. Weston told me that the Commission's eighteen monitoring stations are scattered throughout the U.S., Hawaii, Alaska, and Puerto Rico. They are divided, for operational purposes, into two groups—Eastern and Western, with the station at Grand Island, Nebraska serving as the dividing point.

I asked how the monitoring operator checks to see if a CB station is off frequency.

Mr. Johnson demonstrated by leading me to another position in the main monitoring room. Here, displayed on a 'scope was a "marker blip" superimposed on a gridded scale. Mr. Johnson explained that the "blip"

Continued on page 53

LAFAYETTE CB SUPER VALUES



HE-100L

39⁹⁵
2 For 78.88
 No Money Down

Complete Portable
 Communication For Everyone

NEW!
LAFAYETTE
12 — TRANSISTOR
 CITIZENS
 BAND

"WALKIE TALKIE"
 with SQUELCH

- Separate Microphone and Speaker
- Fully Transistorized — 12 Transistors
- Completely Wired

Complete with
 Leather Case,
 Earphone,
 Antenna, Batter-
 ies, and Crystal



- Uses Inexpensive Penlight Batteries
- No License, Tests or Age Limits
- Pocket Size—Only 9Hx3Wx2 3/4"

SYOSSET, L. I., N. Y. NEWARK, N. J.
 JAMAICA, N. Y. PLAINFIELD, N. J.
 NEW YORK, N. Y. PARAMUS, N. J.
 BRONX, N. Y. BOSTON, MASS.
 SCARSDALE, N. Y. NATICK, MASS.

MAIL THE
 COUPON FOR
 YOUR FREE
 1963 LAFAYETTE
 CATALOG



NEW!
LAFAYETTE HE-75L

13
 TRANSISTOR
 1-WATT CB

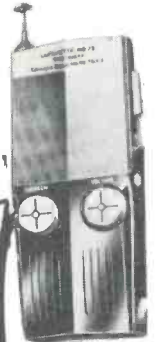

"WALKIE TALKIE"

6650 No Money
 Down
2 For 129.00

- 13 Transistors, 3 Diodes, 1 Thermistor
- Crystal Controlled Receive and Transmit
- Automatic Noise Limiter; Squelch; AVC
- Push-Pull Audio Output
- Superlative "Talk-Power"
- Runs on Penlight Cells or Optional Nickel Cadmium Rechargeable Battery Pack
- Meets FCC Requirements for Licensed Operation Part 19

LAFAYETTE HE-20C CITIZENS BAND TRANSCEIVER

Officially Approved
 for Use in
 CANADA
 Type Approval
 No. 169361029

109.50

- 8 Crystal Controlled Transmit Positions plus 8 Crystal Controlled Receive Positions
- Tuneable over all 23 Channels
- Built-in Power Supply for 110V AC or 12V DC
- Complete with Matched Crystals for Channel 9



LAFAYETTE RADIO ELECTRONICS

LAFAYETTE RADIO ELECTRONICS DEPT. S9G3
 P.O. Box 10, Syosset, L. I., N. Y.

Send me the
 Free 1963 388-
 Page Lafayette
 Catalog

\$ _____ enclosed for Stock No. _____, shipping charges collect.

Name _____

Address _____

City _____ Zone _____ State _____

READ THAT SCHEMATIC!

THE ARTICLE ON TOP OF YOUR REQUEST LIST

by JIM GIBSON, 2W7610

Just as you can't tell the players without a scorecard, you can't tell what's inside your rig without a schematic. And if you don't know what's inside how are you going to make *correct* repairs or modifications.

Learning to read a schematic is not the magical thing many operators think it is. Actually, it's just an electronic shorthand with a *few* symbols. Notice the word *few*. Many of the symbols use a basic design with a slight modification for a specific type—once you know one you really know them all. For example, look at the symbol for a resistor, notice that it is a zig-zag line. A tapped resistor, such as might be used in a power supply is pictured as exactly that, a resistor with a tap. And a variable resistor, such as used for a volume control is just a resistor with a slider to select the correct value. Notice, the symbol for a variable resistor is just that, a resistor with a slider.

Capacitors are handled the same way; notice in the basic symbol that one line is curved. The curved line denotes the outside foil of the capacitor. Usually the outside foil is used as the capacitor shield and in grounded, but it doesn't have to be. The electrolytic capacitor, such as used for power supply filtering *must* be connected with the correct polarity (or boom), so the symbol for electrolytic has a specific positive (+) indication. The variable capacitor again is the basic symbol but with an arrow indicating that it's variable (The arrow always indicates variable whether it's capacitors, resistors or coils.)

To make things easy for you we show the symbols for practically all the components used in a CB rig. Undoubtedly your rig is going to have a symbol that's not shown (but we tried hard).

There are a few troublesome symbols which require explanation. A particular trouble spot is the diode, usually found in the power supply, noise limiter and squelch circuits. The diode is usually shown with a "+" denoting the cathode, but it doesn't have to be. Many manufacturers don't show the "+", so you'll have to remember that the "bar" is the cathode. Most times the diode you use for replacement will have the diode symbol so all you'll have to do is orient the symbol to conform to the one you remove. But sometimes there will be no symbol, perhaps on the replacement or the defective original. When the symbol isn't used the diode will have a series of color bands or one black band. What to do? The band closest to the end, regardless of the number of bands, is the cathode (equivalent to the "+" end of our symbol. On unmarked diodes the *red* end is the cathode (+).

Speaker symbols rarely show the speaker impedance, however, in tube rigs it is usually 3.2 ohms. Whenever you replace a speaker, or add an extension look for an impedance value on the schematic or parts list; if there are no values given assume 3.2 ohms. Transistor rigs are a different story; they can have any impedance speaker. Because the impedance is not usually standard the schematic will generally indicate the speaker impedance.

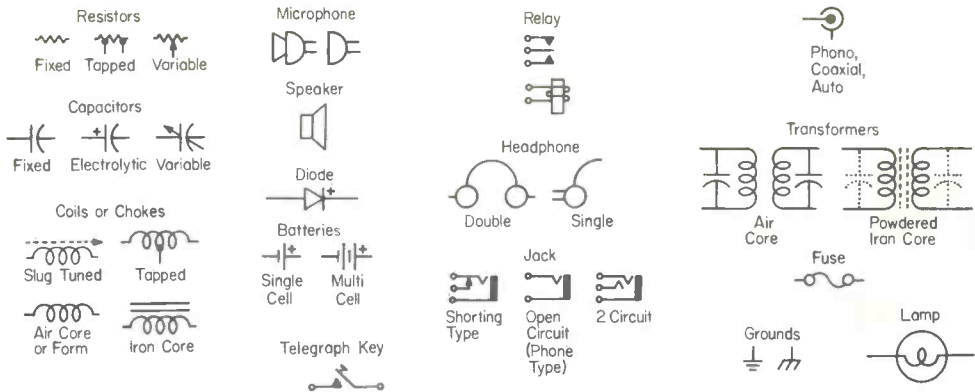

An IF transformer is indicated by the transformer symbol shown. Usually the IF frequency is indicated on top of the symbol. Air core IF transformers which are adjusted by variable capacitors use the Air Core symbol with the capacitors indicated as variable. Iron Core IF transformers indicate variable adjustment (usually) by two small arrows, one directly over each coil.

RF transformers are a different story. Usually they are made specifically for your rig and only the symbol will be shown, no values. If you have to replace them inquire as to how to go about it from the distributor.

Switching relays are a simple matter to troubleshoot if you remember that the wiper-arm, or movable contact is shown in the symbol as a straight bar. The stationary contacts have a triangular contact point attached to a bar. While we show but one set of con-

tacts, relays used in CB rigs can show up to five. Each set of contacts is grouped about its own wiper.

Shorting jacks have the normal, or moving contact closest to the heavy vertical line which indicates the jack's frame. To avoid confusion in the future, notice the difference between the shorting jack, which is usually used in the final plate or speaker circuit, and the 2 circuit jack which is usually used for

Transformer Color Codes

Power Transformers

Primary leads.....	Black
High Voltage plate leads.....	Red
Center tap.....	Red and Yellow striped
Rectifier filament leads.....	Yellow
Center tap.....	Yellow and Blue striped
Filament #1.....	Green
Center tap.....	Green and Yellow striped
Filament #2.....	Brown
Center tap.....	Brown and Yellow striped
Filament #3.....	Slate
Center tap.....	Slate and Yellow striped

Audio Transformers

Blue.....	Plate lead
Red.....	B+ lead
Brown.....	Plate lead (may be blue when polarity is unimportant)
Green.....	Grid lead (interstage or line xfrmr)
Black.....	Grid return, usually grounded. Also speaker leads on output transformer.

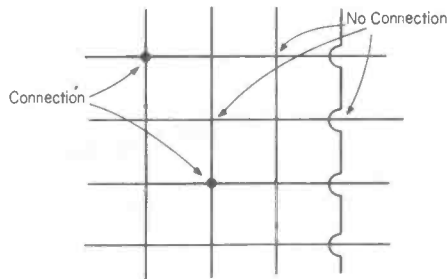

When dots are used only wires at the dots are connected.

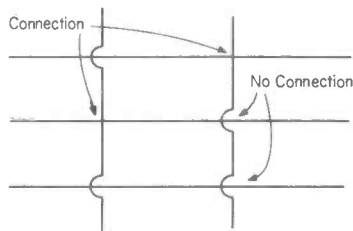

When dots aren't used, wires that are not bridged are connected.

the mike input.

Coaxial jacks, phono jacks used for the antenna jack, and auto type jacks are usually

MANUFACTURER'S CLOSE-OUT



Manufacturer makes way for the new models by selling out these superbly designed and styled 5 watt all transistor CB rigs. A fortunate purchase allows us to offer these 4 channel transceivers for only \$109.95 while they last. Checked out with one channel installed. Give alternate choice of channels. Extra channels only \$4.95. Hurry, they won't last long at this price.

Paulin Sales Co.

Box 122 Upland, California

this "S" Meter



Model
540

Indicates your signal strength instantly
ONLY \$1388 NET

- A SECO PLUS—the first transistorized "S" Meter on the market . . . introduces no loading on AVC circuit!
- Ideal for CB, AM and FM tuners, ham, TV, and antenna orientation
- Illuminated "zero" to "30 db over 9" meter—also controls for zero set and sensitivity
- Completely self powered—operates on standard 9 v battery
- Can be built right into your set or attached anywhere with suction cup base
- Styled to make a handsome matching set with the Seco Signal Filter noise limiter and controllable squelch

See your electronics distributor or use the coupon below to order your Seco Model 540 "S" METER.



SECO ELECTRONICS, INC.

1241 S. Clover Drive, Minneapolis 20, Minn.

Please send (Qty) _____ "S" Meters postpaid

check money order for \$_____ (\$13.88 each) enclosed.

PRINT

NAME _____

ADDRESS _____

CITY _____

STATE _____

14 • 59 • July 1963

indicated by the symbol shown, which is the phono jack.

A sore spot to the beginner is usually how the connection is made. Usually a connection is indicated by a dot, as in Fig. 1. The dot indicates that all wires at the dot are connected together. When dots are used to indicate connections, other wires may cross, but no-connection is indicated if the wires cross without the dot. Usually, no-connection will be indicated by one wire bridging another. Sometimes, as in Fig. 2, when no-connection is indicated by a bridge, a connection is any point where two wires cross (dots will not be used).

Handling schematics is no problem once you get the hang of the symbols and the different ways a connection is shown. From then on your only problem will be with the rare, but ever present, manufacturer whose drafting department insists on coming up with new designs or uses a template from 20 years ago. A quick example of the confusion caused by obsolete templates: Rare is the "imported" schematic that doesn't show a capacitor as two straight plates (no curve to indicate negative) and leaves the guessing of polarity to you. But the usual schematic will present no problems once you learn the symbols, and you will be able to discuss your rig like a pro.

S9



"I know it ruins the looks o' the place, but at least it's legal."

S9—GUARANTEED Largest CB Circulation!

NEW

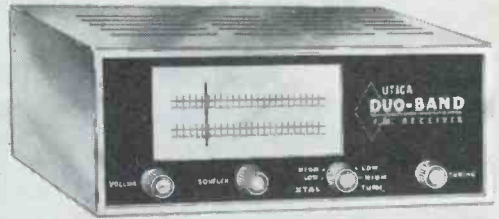

FROM UTICA

A) UTICA'S BRAND NEW DUO-BAND FM RECEIVER

for low (30-50 Mc.) and high (152-174 Mc.) band monitoring of police, fire and business mobile frequencies. Crystal controlled positions for high and low bands, illuminated slide rule dial, dual conversion superhet receiver, squelch, tuned RF stage, crystal controlled 2nd stage oscillator and Duo-Band is temperature compensated for drift control. 110 v. AC only.

- Chrome Steel Cabinet \$164.95
- Accessory speaker in matching cabinet \$ 12.95

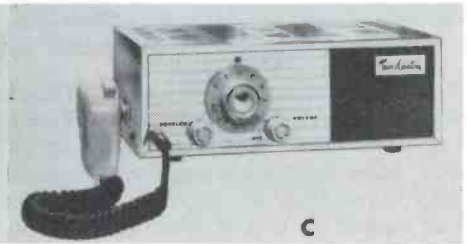
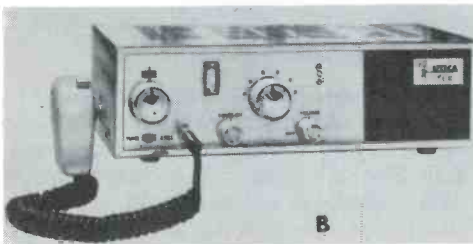

B) FOR THE ULTIMATE IN CB PERFORMANCE IT'S T & C II

featuring dual conversion 6 channel crystal controlled superhet transceiver with tuneable receiver. S meter and signal strength output indicator, external crystal socket, auxiliary speaker terminal and universal power supply.

Chrome Steel Cabinet \$199.95

C) THE RUGGEDLY HANDSOME MC-27

is a dual conversion 6 channel crystal controlled superhet transceiver with superior squelch circuit, automatic volume control and universal power supply.

Chrome Steel Cabinet \$179.50

FREE

LITERATURE

- Duo-Band
- T & C II CB Transceiver
- MC-27 CB Transceiver
- Gizmotchy Antenna
- Selector Box for Gizmotchy
- Ground Plane Antenna
- Buddy Whip Mobile Ant

Name _____

Address _____

City _____ State _____ **D**

UTICA COMMUNICATIONS CORP.

2917 W. IRVING PARK RD., CHICAGO 18, ILLINOIS
 Subsidiary of Continental Marine Corp. Another subsidiary, Checker Electronics Corp.

Special club subscription rates for S9

July 1963 • S9 • 15

WATT'S THE OUTPUT?

A SIMPLE CB RF WATTMETER

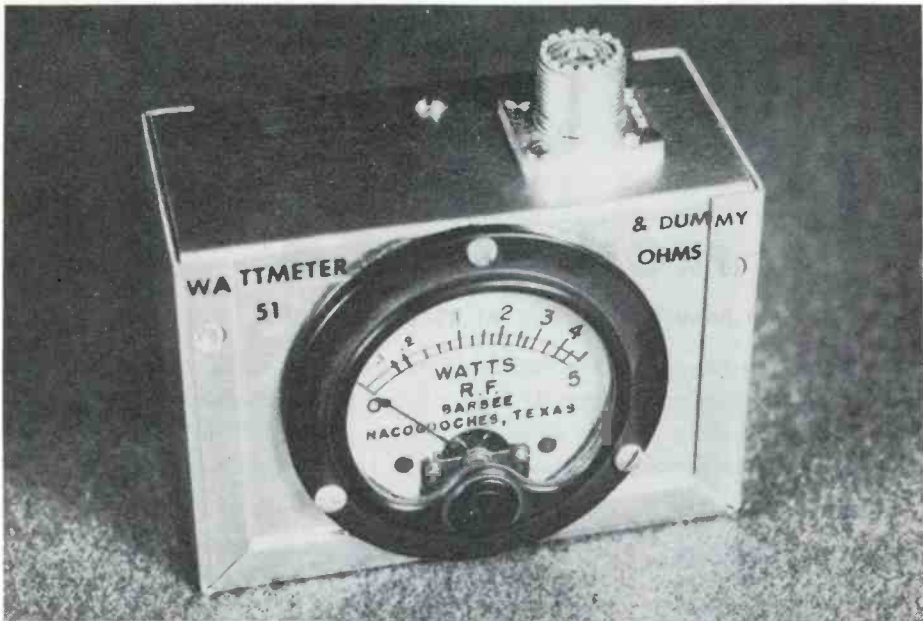

by **BASIL BARBEE, 9W0831**

Every CB transmitter (except hand-held ones) is designed for 5 watts *input*. Every CB operator knows that what counts is the *output*. Most transmitter manufacturers are usually vague about stating their claims for power output, so that it is desirable to be able to compare one make with another by *measuring* the output. In developing or servicing CB transmitters, two useful accessories are the dummy antenna and the wattmeter. The dummy must be used during prolonged tests so as not to interfere with other stations, while the wattmeter assists in achieving efficiency by telling us how much output we are getting for our five watts input.

The little instrument shown in Fig. 1 combines both dummy antenna and wattmeter in one small aluminum box. Operation is simplicity itself since there are no switches or other controls of any kind. The transmitter antenna receptacle is merely connected to the receptacle on top of the instrument with a short length of "50-ohm" coaxial cable; the dummy absorbs the transmitter's output, while the wattmeter measures it.

The schematic diagram, Fig. 2, shows how the few components are connected. $R_{1A,B,C,D}$ is the 51-ohm dummy antenna, composed of four 51-ohm, 2-watt non-inductive composition resistors in series-parallel. The 8-watt dissipation rating of R_1 , compared with the 5-watt maximum indication of the meter, assures adequate safety factor so that the resistance of the dummy will not change due to overheating. The value of 51 ohms was chosen because it is a standard value of resistor near enough to the actual values of characteristic resistance of "50-ohm" coaxial cables for satisfactory accuracy. For instance, the two most-used types of coax, RG-8/U and RG-58/U are rated at 52 and 53.5 ohms respectively.

A slightly simpler way of measuring power would have been to insert an R.F. ammeter in series with the dummy antenna, but such meters have several drawbacks: 1. They are expensive, especially when accurate at high frequencies and capable of measuring the small current (0.31 amperes) involved; 2. Their scales are crowded and inaccurate at

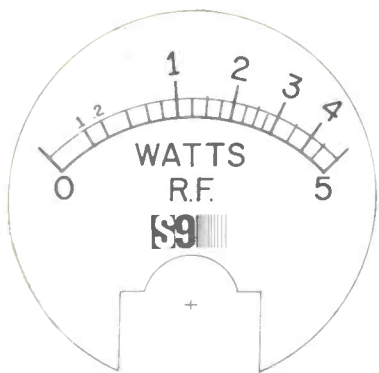

This is the face of the meter, shown in its actual size. Just cut from this page and you're all set.

the left end; and 3. Their readings are affected by amplitude modulation (as much as 22.5% at 100% modulation).

A more satisfactory solution is used here: The R.F. voltage across the dummy R_1 is rectified by the 1N34 diode D_1 , charging the bypass condenser C_1 with a D.C. voltage nearly equal to the peak value of the R.F. voltage. The 150 microamp meter I_1 , in conjunction with the multiplier resistor R_{2A} and R_{2B} , becomes a voltmeter with a scale calibrated in watts to measure the D.C. voltage across C_1 .

D_1 and C_1 are too small to be readily seen in Fig. 3, but are mounted with as short leads as practical between the coax connector and the nearest terminal of R_2 .

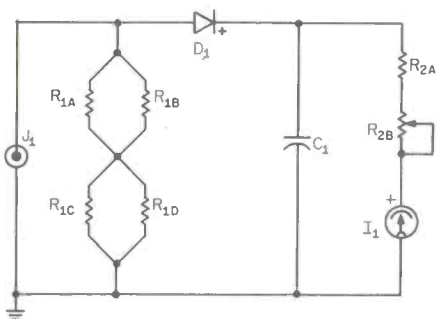

PARTS LIST

- C_1 220 pf disc ceramic condenser
- D_1 1N34 germanium diode
- I_1 150 microamp, 2 3/4" D. C. meter
- J_1 50-239 coax receptacle
- R_1 4-51 ohm, 2 watt, 5% composition resistors
- R_{2A} 100,000 ohm (0.1 megohm), 1/2 watt resistor
- R_{2B} 50,000 ohm variable resistor (rheostat or potentiometer)
- Cabinet: 2 x 2 3/4 x 4" aluminum box, Bud CU-3015-A or equivalent

The BIG Switch Is To S9

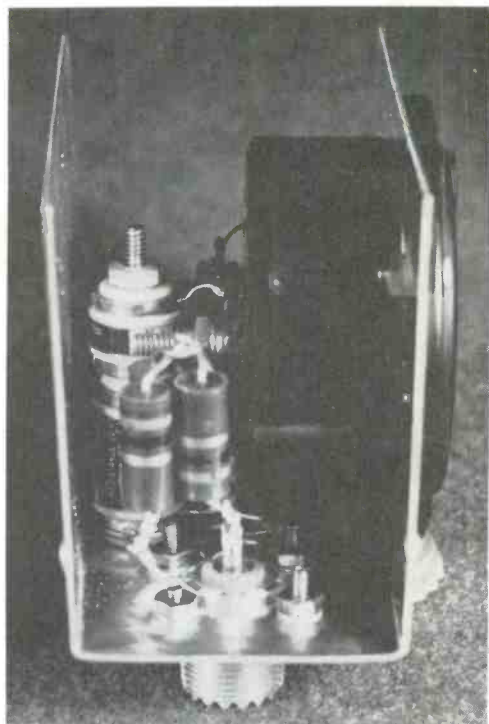

The 150-microamp meter will need a new scale calibrated in watts. A scale suitable for most 2 3/4" meters is reproduced in Fig. 4. Should you want to draw your own, the various divisions on the new scale should correspond to those of the old one according to the formula $I_M = \sqrt{P}$ uA, where I_M is the reading on the old scale in microamps and P is the corresponding reading on the new scale in watts. The table below lists the points used in drawing the scale shown in Fig. 4.

P (watts)	I_M (uA)	P (watts)	I_M (uA)
0.1	21.2	2.0	94.5
0.2	30	2.25	100.4
0.4	42.4	2.5	106
0.6	51.9	2.75	111
0.8	60	3.0	116
1.0	67	3.5	125.2
1.25	75	4.0	134
1.5	82.9	4.5	142.1
1.75	88.5	5.0	150

Adjustment of Completed Instrument

Temporarily connect a 0.22 uf. or larger paper condenser across C_1 . Apply an accurately measured 16 volts r.m.s. at 60 cycles to J_1 , and adjust R_{2B} for a reading of 5 watts on the meter. Remove the temporary condenser and the meter is ready for use.

July 1963 • S9 • 17



AUDIO-BILITY WITH DYNAMIC MIKES



AN IN-DEPTH LOOK AT CB DYNAMIC MIKES

by JIM KYLE, KEG3382



Satisfied with the performance and range of your CB rig? If you're not, chances are it's time you took a look at the characteristics of the mike you're using.

Most of us sort of tend to take the mike for granted; one comes with most transceivers, and in the absence of better information we accept this unit (whatever it may be) as the one the manufacturer thought best for his transceiver.

But far too often, the choice of a mike to pack with a transceiver depends as much upon cost factors as on the features of the microphone itself—and if this happened to be the case with *your* equipment, you may find a drastic change in system performance simply by substituting a communication-tailored mike!

Unfortunately, substituting a microphone isn't quite so simple a matter as you might think. It's seldom that you'll find two different types of microphones which are completely interchangeable with each other—and even more rare to be able to determine the exact characteristics of the mike you have to start with. Mere physical resemblance is *not* enough since most manufacturers supply special-order products to other firms and these special products frequently differ in important points from the regular line.

Even a broad breakdown into types such as crystal, ceramic, and dynamic is often of little meaning, since a good crystal mike (when new) will outperform a poor dynamic—and may or may not be interchangeable with it.

As the title of this article indicates, the writer believes a good dynamic mike is great for effective communications—but to achieve this top performance it must be properly employed, and in order to do this one has to know how a dynamic differs from other types.

Some articles may have led you to believe that a so-called "high-impedance" dynamic may be substituted directly for a crystal or ceramic mike; this is *sometimes* true but unfortunately not always.

And friends who may have tried the substitution without enough data may tell you that a dynamic is boomier and harder to understand than a ceramic or a crystal. This can be true but need not be.

To avoid these traps, let's get just a wee bit technical for a few minutes and find out how these mikes work.

A ceramic unit produces relatively high electrical output, but requires an exceptionally high load impedance for extended bass reproduction. This means simply that, to use one for hi-fi recording, you must have a 3.3 to 4.7 megohm resistor from grid to ground in the first audio stage.

Of course, we are not doing hi-fi recording. We're trying to communicate via radio, and do it within a 5-watt power limit. This, in turn, limits the audio of our modulators to 2½ watts *maximum* if we're going to stay legal—and our problem is to make the best use of this 2½ watts we're allowed.

Extensive studies by telephone company researchers have shown that most of the *power* in the human voice is concentrated in

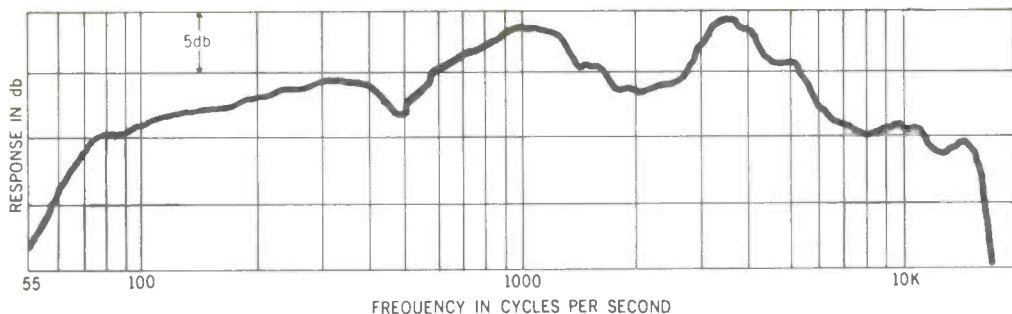

Fig. 1. Communications mike response curve.

the extreme low frequencies, while most of the *communications effectiveness* is concentrated in the midrange between about 300 CPS and 3,000 CPS.

Thus, if we shave off the frequencies below 300 CPS we can use our 2½ watts strictly for communications effectiveness; if we transmit these frequencies, we will be splurging our limited power on non-essential parts of the voice.

The reason for going into all this here is that the high-resistance-load requirement of the ceramic mike can be put to excellent use (and this is frequently done) simply by providing a load resistor whose value is tailored to result in good response *above* 300 CPS but very little output below this level. For this reason, you'll usually find the audio input grid resistor has a rather moderate value, usually less than 1 megohm.

Now what happens with a dynamic mike? This type, which is built something like a

miniature loudspeaker with a rugged case, has electrical output roughly similar to a ceramic (often just enough less, though, to give the impression of vastly lowered output) but does *not* have the high load requirement.

Thus, when an existing ceramic is replaced with a dynamic, you have two effects at once: the overall power goes down slightly, but the bass response comes way, way up. The result? The "boomy" effect mentioned earlier. But it's not the fault of the mike, and before we're through we'll show you how to avoid this problem.

At this point, you may be asking "Why bother with all this when a lot of good ceramics are listed in every catalog?" It's a fair question—but there's a very good answer.

If every microphone had a perfectly smooth frequency response curve, then no one mike would be appreciably better than any other. But every different type of mike, and every different model in each type, dif-

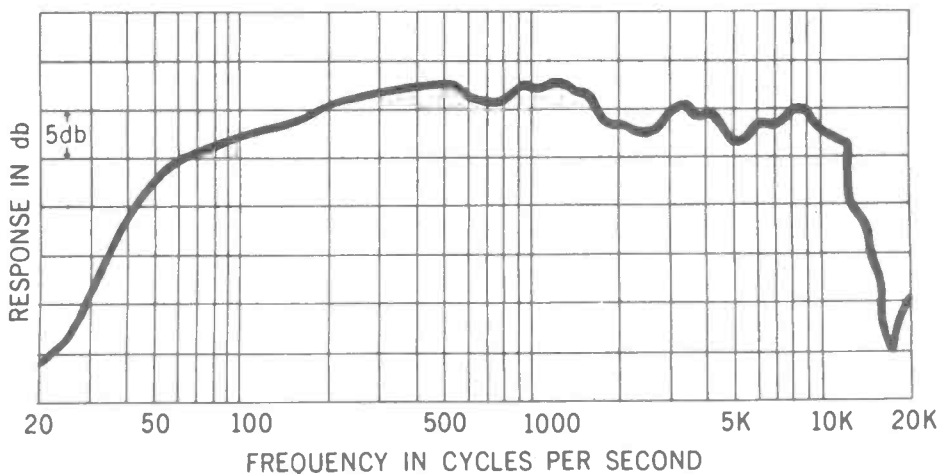

Fig. 2. Response curve of a typical dynamic mike, this one happens to be a University Model 70.

fers slightly in the way it responds to incoming sounds. We can go even farther—every different mike of each model varies slightly! The published response curves we see are usually averages for each model.

While both ceramic and dynamic microphones have response curves which are actually rather ragged—Figure 1 is a representative curve of a communications-model mike—the ceramic has a tendency to vary more from mike to mike within a model than does the dynamic. The reason is simple; every physical object possesses what is known as mechanical performance, and this mechanical resonance is what gives rise to the peaks and valleys in the curves. In the ceramic, the mike element *itself* is a relatively large slab of piezoelectric ceramic material, which has a mechanical resonance. To this must be added the resonances of the diaphragm, its suspension, the case, etc.

With a dynamic, on the other hand, the only significant resonances are those of the diaphragm, suspension, and case. The mike element is simply a coil of wire attached to the diaphragm (usually) and any resonance associated with this is absorbed in the diaphragm itself.

This indicates that in general one can expect a dynamic mike's curve to be at least a little smoother than that of a ceramic of comparable quality.

In addition, the resonances of the ceramic element tend to vary from unit to unit, while those in the dynamic appear to be more consistent throughout a model line.

"So what?" you may ask. "This is all interesting, but what has it do do with me?"

Go back to our 2½-watt audio power limit. This 2½ watts is the *peak* power we are allowed. Communication, on the other hand, is determined by *average* power. Assuming that we have perfectly flat mikes, peak and average power have a definite ratio to each other. But if our mike has a 10-db peak at some one frequency within the 300-3000 CPS communication range, then this *single peak* determines our 2½-watt point. Our *average* (or effective) power must be 10 db lower—and since 10 db represents a ten-fold reduction in power, we are actually holding ourselves to one quarter of a watt talkpower!

This example is a bit more extreme than you're likely to encounter in practice, but it accounts to a large degree for the easily

noticeable differences between different mikes! The smoother the mike response, the louder it will sound—if the modulator has enough gain.

Which brings us right back to the gain problem—and also to that little matter of shaping the bass response, since many of the most popular CB rigs around these days were originally designed to use ceramic mikes and depend to a large degree on mike loading to cut the unneeded bass out.

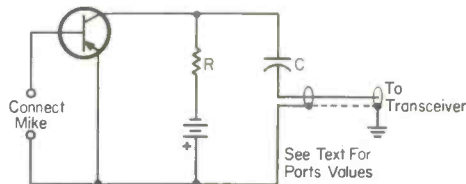

Fig. 3. A simple dynamic mike preamp using a single transistor and a few other components. The values of the components are discussed in the text. The unit is easily constructed in a small Bud Minibox or other mental container.

The simple transistor preamp shown in Figure 3 will overcome both problems for you. Any of the easily available PNP audio transistors (CK722, 2N107, etc.) will work nicely in this circuit, and hardly anything is critical. Gain is adjusted by changing the value of the resistor, while the bass cutoff is controlled by changing capacitor value. The larger the resistor the higher the gain, and the larger the capacitor the more bass you'll have. While the values shown on the schematic will probably be preferred by most users, feel free to vary either of them in either direction. Nothing will be hurt so long as you don't go below 15,000 ohms or over 470,000 ohms with the resistor, or below 0.0001 ufd. or over 5 ufd. with the capacitor. The battery, incidentally, can be any 3-volt source; mercury cells have longest life but cost the most. Use a battery—don't try to take voltage from the transceiver power supply or the vehicle battery.

IMPORTANT: Addition of this preamp to your transceiver can possibly cause over-modulation; for this reason the unit should not be operated on the air afterward until you have had modulation percentage measured and certified by a licensed technician!



new and available now!

"MESSENGER TWO" CB TRANSCEIVER



"TONE ALERT"

SELECTIVE CALLING SYSTEM

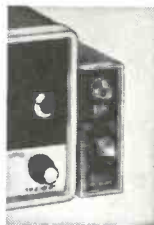
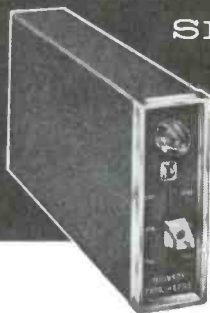

- 10 channels at flip of a switch — illuminated indicator!
- Increased sensitivity, high adjacent channel rejection!
- New . . . high efficiency noise limiter circuit!
- Provision for plug-in selective calling system!

Here's the new "Messenger Two" — with everything you've ever wanted in CB transceiver! Basic circuitry is patterned after the popular "Messenger". Highly efficient circuit design makes full use of maximum legal power . . . delivers a penetrating signal that "outperforms 'em all!" Looking for maximum receiver sensitivity? This unit is hot — pulls in signals you wouldn't know were around with less sensitive equipment . . . and adjacent channel rejection is tops! Tired of noisy receiver? New, noise limiter circuit in the "Messenger Two" lets you know what QUIET really means in a CB rig! Positive acting "squelch" and automatic volume control circuits — 10 channel coverage — push-to-talk microphone. Only 5 7/8" x 7" x 11 3/8", easy to install anywhere.

Cat. No. 242-162 115 VAC and 6 VDC. . . . \$169.95

Cat. No. 242-163 115 VAC and 12 VDC. . . . NET

5 CHANNEL "MESSENGER" TRANSCEIVER . . . Now at a new lower price, the big seller in the CB field! Excellent sensitivity and selectivity — punches out a power-packed signal! "Squelch" circuitry.
Priced from \$139.95 NET



1 WATT AND 100 MILLIWATT "PERSONAL MESSENGERS"—Compact, 11 transistors and 4 diodes. Superhet receiver with exclusive tuned RF amplifier gives twice the sensitivity and 40% more range than similar units with conventional circuitry—more output than similar units with same rated inputs! Priced from \$109.50 NET

**SEE YOUR DEALER-DISTRIBUTOR
AND ASK FOR A DEMONSTRATION**

BRAND NEW! A complete selective calling system with 37 different available tones!

The ultimate for any CB installation — designed for serious industrial, police and emergency use. Mutes speakers on your units until one calls another — then automatically your stations receive audio note and indicator light flashes "on", remaining lighted until call is answered. Eliminates annoyance of hearing "skip", electrical noise, or transmissions not meant for you!

- Not a kit, ready to go! Plugs into "Messenger Two", fast hook-up to your existing equipment!
- Sharp selectivity guards against random triggering which broad response units can't prevent!
- Wide range of tones permits 37 different systems to operate on the same channel without overlap. Plug-in reed locks unit "on # channel"—no missed calls due to "wrong" position on selector switches!
- Universal mounting bracket for left, right or remote mounting under dashboard or desk!
- Tone signal heard beyond normal voice communication distance, increasing coverage by miles!

Only 1 1/2" wide x 4" high x 7 3/4" deep — wired with all cables and hardware.

Cat. No. 250-810 115 VAC and 6 VDC. \$59.95

Cat. No. 250-811 115 VAC and 12 VDC. NET

FREE! 4-COLOR BROCHURE!



E. F. JOHNSON CO

® 7010 10th Ave. S.W. • Waseca, Minnesota

Please rush "Messenger" details to:

NAME _____
ADDRESS _____
CITY _____ STATE _____

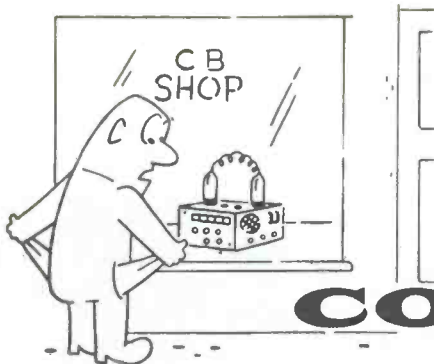

ON THE COUNTERS

Quite a few new and interesting things have come along for CB'ers in the past few weeks. Here they are.

75L has a rechargeable nickel cadmium battery. The company will be pleased to send full details upon receipt of your request.

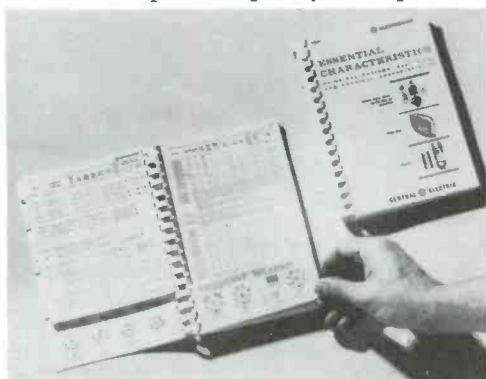
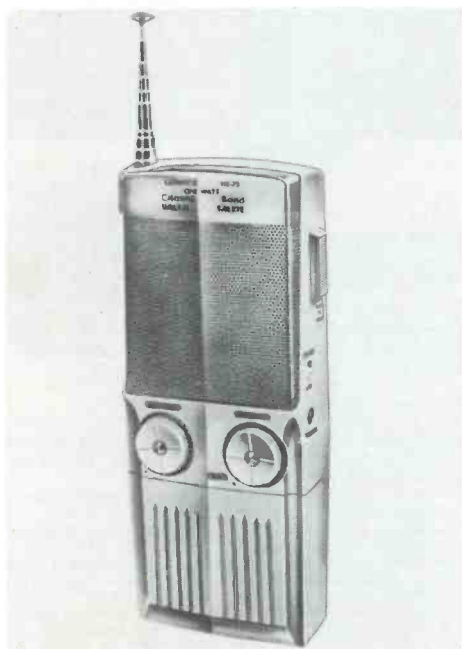

You experimenters will get some use from General Electric's new edition of the G.E. Tube Handbook. It's priced at \$1.50 and is available from The General Electric Company, 3800 N. Milwaukee Ave., Chicago, Ill. It's quite a fattish book and has "strip" pages which makes it easy when locating base diagrams for specific tubes.

Lafayette Radio, Dept. S9G-3, P.O. Box 10, Syosset, L. I., N. Y., has popped up with another walkie-talkie unit, the HE-75L. This is a 1-watt Part 19 unit which contains 13 transistors, 3 diodes, 1 thermistor. It is priced at \$66.50 for one or two for \$129.00. The transmitter is a 2-stage job with silicon output transmitter and Lafayette claims that the unit provides up to 40% more range than standard Part 15 100 milliwatt units. The receiver is a superhet with a push-pull audio section. Other features an automatic noise limiter, a variable squelch, automatic volume control and a local/distant switch. The HE-

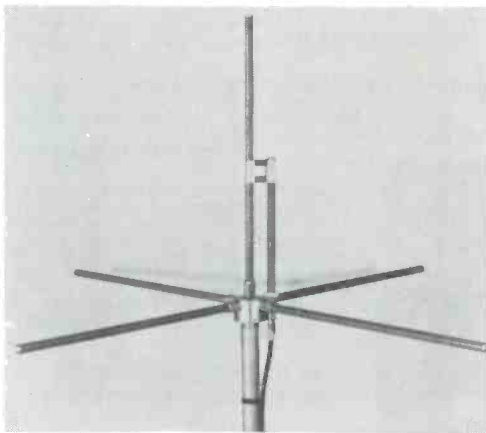

The Herb Kreckman Company of Cresco, Pa., makers of Kreco Antennas, is now offering two new all grounded CB ground-plane antennas. The model GP-41A mounts on 1 1/4" pipe threads and has a vertical radiator of 3/4" aluminum tubing. The model GP-42A has a vertical element constructed of similar tubing which extends two feet below the ground-plane for mounting to a tower or other vertical structure. Both models are fed with RG-8/U and are factory peaked to any specific frequency desired. The company claims static and noise rejection and complete protection from lightning. Ask Herb to send you more info.

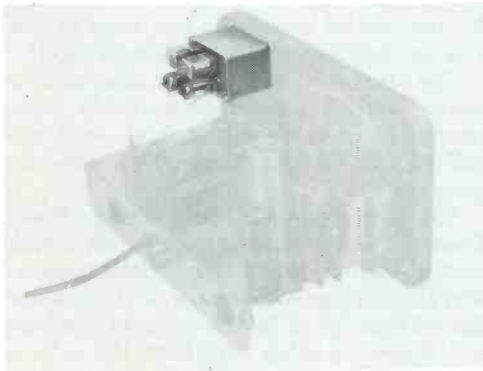

Hammarlund Manufacturing Co., 53 West 23rd St., New York 10, N. Y., has issued forth a TD-10 decoder unit. This is a squelch adapter which silences your receiver until a coded tone of specific pitch and duration is received. The decoder is 3 inches long, 2 inches wide and 7 1/8 inches high. The weight is 12 ounces.



Eltec Laboratories, Inc., 30 Alsop Avenue, Middletown, Conn., announces an extremely accurate and versatile CB frequency standard, the Model 600. With an accuracy of

59—GUARANTEED Largest CB Circulation!

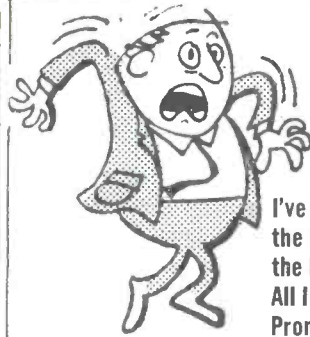

I've tried them all ...
the magazines ...
the books.
All I get is talk, talk,
Promises, promises ...

Instead of the information
I want!



Why can't I get the news
expressly suited to my
wants and needs?
Which one of the many
will give me the right
combination of reading
quality, humor, and useful
information I desire?

?? ? ? ? ? ?

GADZOOKS!

There IS

Such A Magazine ...



the citizens band journal

... we gratefully accept subscriptions.
Postage-free envelope in the rear of this issue.

.0002% and a range of from 25 mc/s to 54 mc/s. The unit is claimed to have excellent stability over its entire range and can be easily checked against National Bureau of Standards radio station WWV in the field. In addition, it can also be used from 10 kc/s on other applications for calibrating 100 kc/s oscillators and spot checking frequencies all the way to 54 mc/s. Price of the unit is less than \$350. It has a multitude of exotic features far too detailed to discuss here, but a note to the company will bring you an in-depth spec sheet on the Model 600.



E. F. Johnson Co., Waseca, Minn. has a new "Messenger" radio paging system which should be of interest to many CB'ers. The system is designed to alert selected individuals by a radio tone or voice message broadcast from a central point directly to a tiny pocket receiver carried by the individual. There are many applications for this interesting paging system, which consists of several separate components. Johnson can give you all particulars on prices and applications if you send them a card or letter.

S9 Lab

Reports

THE ELENCO "POWER GAINER"

Since people began to find out how much they could boost talk power by addition of compression amplifiers to their transceivers, seems like everyone has been coming out with such gadgets.

Often, when a device catches on, the pioneer who first opened up the field gets forgotten. Not so this time, though—because Electronic Engineering Co. and its "Power Gainer" (plugging away even before CB came into its glory) are right up there at the forefront still.

And despite all the newcomers, the "Power Gainer" still has a couple of features not matched by any other unit.

For instance, it's the *only* one we know of which gives you complete control of all operating characteristics, right at your fingertips. Every adjustment possible on the unit is brought out to the front panel with a calibrated dial. Once you determine the settings for the various conditions *you* want to use, you can log them and know they're right!

The other feature lies in the tube complement. Most commercially available audio processing units consist of single-tube amplifiers. The "Power Gainer" is a two-tube unit.

The power supply hookup of the "Power Gainer" is worth mentioning also. All models feature built-in power supply, which means that the designer didn't have to worry about the wide range of B-plus voltages available in transceivers (they vary from 180 volts to 390 depending on the brand of your transceiver, which means that compression amps designed to take power from your rig *must* be built to take that range). For mobile use, the "Power Gainer" connects to the then-unused 110-volt winding of the transceiver power transformer!

Three cables connect the "Power Gainer" to the transceiver; one is the input for the "Power Gainer", the second is its output, and the third samples modulator output of the transceiver to develop the compression voltage used. You have a choice of two methods of hookup, but the "series microphone" connection described in the instruction booklet is to be avoided whenever possible as it can easily restrict the range of control possible if your mike has low output (a point, incidentally, not mentioned in the instructions!).

Instructions for hookup of the "Power Gainer" to the transceiver are clear and concise, and we had no trouble with them. We only wish we could say the same about the description of operation! Perhaps the next edition of the instruction book might include a handy table up front showing the range

of recommended settings for each control. They're all included in the present theory text, but you have to dig for them.

Since this portion of the instructions appear first, you may easily be so confused by the time you *do* find the table (on page 9) that you don't recognize it.

Even a rearrangement of the present material to present hookup first, adjustment second, and "theory of operation" last would be a definite improvement in the instruction book.

This may sound like a very minor point when we're supposed to be talking about the equipment, but it's just about the only thing we could find wrong with the "Power Gainer". The device itself functions precisely as billed, compressing cleanly and delivering its 6-db (four times) increase in talkpower very nicely.

Back to the instruction book, on the model we tested the layout of cables as shown on page 6 and as it actually was on the back of the unit was reversed—we understand this was due to a model change. Memo to Electronic Engineering: How about silk-screening the nomenclature on the back panel as nicely as it is on the front?

Aside from these two very minor points, we found nothing to criticize. If you don't have a compression amplifier, you need one—and the "Power Gainer" is tried and true.

THE LAFAYETTE RADIO HE-90



The most recent addition to the Lafayette Radio line of 5 watt CB gear is the HE-90, a stripped down, deluxe, low cost transceiver. No, we're not nuts, the HE-90 is all three: stripped, deluxe, and low cost (Price \$94.50). Lafayette picked the best features of their

ORDER NOW

IMMEDIATE DELIVERY FROM STOCK



CADRE

most Powerful
Portable
2-way
Radio
MODEL C-75

INCOMPARABLE FEATURES

Two channel crystal Transmitter and Receiver • One-half watt of audio output power • Fully automatic overload protection • Two-tone high impact cabinet • Built-in, retractable antenna • Push-to-talk switch • Operates continuously up to 12 hours

• Complete with attractive carrying case, plus many other perfect performance features.



10% Down **\$11.00** (\$109.95)

ORDER NOW FROM HAMATEUR HEADQUARTERS

THE Lew Bonn CO.

Distributors of Nationally Known Amateur Equipment

Dept. S9-463 67 South 12th St., Minneapolis 3, Minn.

Call, write or use coupon

Attn: Joe Hatch Federal 9-6351

Place my order for scheduled delivery.

Enclosed find \$_____

Send further details and literature on CADRE MODEL C-75

Name _____ Call letters _____

Address _____

City _____ Zone _____ State _____

other rigs, added a few new ones, and then chopped-off the frills to keep the cost down.

Let's start with the receiver section which utilizes two stages of 1650 kc. IF amplification, giving good gain and decent selectivity (an S9 signal of 50 uv. did not splash into the adjacent channel). The RF amplifier utilizes a Nuvistor for high gain and good for signal-to-noise ratio. Six crystal control positions and variable tuning are provided. The crystal positions are tied to the transmit crystal selector so that either crystal control or variable tuning can be used on all transmit positions.

The good quality noise limiter of Lafayette's other models has been retained, as has the variable squelch. The excellent audio quality for which Lafayette transceivers are well known has been made even better. The receive audio quality is exceptionally crisp and clean, lending to outstanding reception under high noise conditions.

To make life easier for the late-nite operator a headphone output jack is provided which automatically disconnects the internal speaker when the phones are plugged in. The headphone output can of course be used for

a remote speaker. The receiver's output is also connected to one of the terminals on the microphone jack so that a handset can be easily connected without making any modifications to the transceiver's wiring. For measurements and critical tuning an S-meter is provided.

The transmitter section is essentially the standard Lafayette circuit with some improvements. It is six channels, using overtone crystals, and it delivered slightly over 3 watts output. To insure maximum RF output at all times a relative RF power output meter is provided. After the antenna is connected you adjust the pi-net output circuit for maximum meter reading. At peak reading the transmitter is tuned on-the-button. The transmit audio quality is very good; there is plenty of reserve mike gain and 100% modulation is easily obtained.

Among the minor features are an adjustable TVI filter, electronic switching, a Koil-Kord PTT mike, and switch selected spot-calibrate. Now you may ask what they left off, since we said the unit was stripped. Well,

Continued on page 52

TRAM

**CB EQUIPMENT
PUTS RANGE
BETWEEN
YOUR
STATIONS!**



TR-70B

**DESIGNED, BUILT AND GUARANTEED TO BE
THE BEST MOBILE YOU CAN BUY!**

RECEIVER

Sensitivity - .1 uv. for 300 milliwatts of audio
Selectivity - 5 kc. @ 6 db. Adjacent channels 60 db. down
Signal to Noise Ratio - .3 uv. for 10 db.

TRANSMITTER

70% or better Transmitter efficiency provides 3.5 watts guaranteed minimum RF Output with 100% High Level Modulation.

Incredible weak signal readability-plus the unmistakable signs of Quality.

As well as standard TRAM Features and Performance!

To hear from TRAM by return mail, write for detailed information and specifications.



TRAM ELECTRONICS

P. O. BOX 187, DEPT. S 7 WINNISQUAM, N. H.

add more
voice punch
to your
CB rig...

less
10-9 and 10-1
more "solid"
10-4's

SHURE
201 CB
ceramic
improvement
microphone



"SHAPED" VOICE RESPONSE
... patterned after professional mobile
and SSB amateur radio response curves
... assures maximum intelligibility.
PROFESSIONAL QUALITY DESIGN,
CONSTRUCTION ... performs as good
as it looks.
"ARMO-DUR" VIRTUALLY INDE-
STRUCTIBLE CASE ... shock-shatter-
corrosion-rust-and-weather-proof.

LONG-LIFE SWITCH ... guaranteed a
full year.

SUPERIOR COILED CORD ... won't
kink, crack, peel or lose resiliency.

"LIFETIME" HANG-UP BRACKET ...
positive lock in, easy snap out.

CB net model 201—\$10.80

Write for literature:

SHURE BROTHERS, INC.
222 Hartrey Avenue, Evanston, Illinois

CITIZEN BAND STANDARDS BY SONAR

When performance is critical and reliability a necessity SONAR CAN BE DEPENDED UPON. CB standards of Sonar must and will always be above and beyond what is expected. Write for full particulars.



MODEL G Featuring the NEW Sonar noise silencer. Dual conversion • RF output meter • Signal strength meter • Crystal spotting switch • illuminated panel • 8 channels crystal-controlled • Receiver tunes 23 channels • Class "B" modulation

Complete with 1 pair of
crystals and microphone

\$229⁵⁰



MODEL E FCC type accepted • 8 channels, crystal-controlled transmitter/receiver • Tunable receiver for 23 channels • Powerful transmitter 100% Class B modulated • Automatic noise limiter • Lightweight, compact.

Complete with 1 pair of
crystals and microphone

\$179⁵⁰

SONAR RADIO CORPORATION

73 Wortman Ave., Brooklyn 7, N.Y.

Please send me complete information on

Model E Model G Dept. 253

NAME.....

ADDRESS.....

CITY..... STATE.....

Write to our advertisers for special product news

July 1963 • S9 • 27

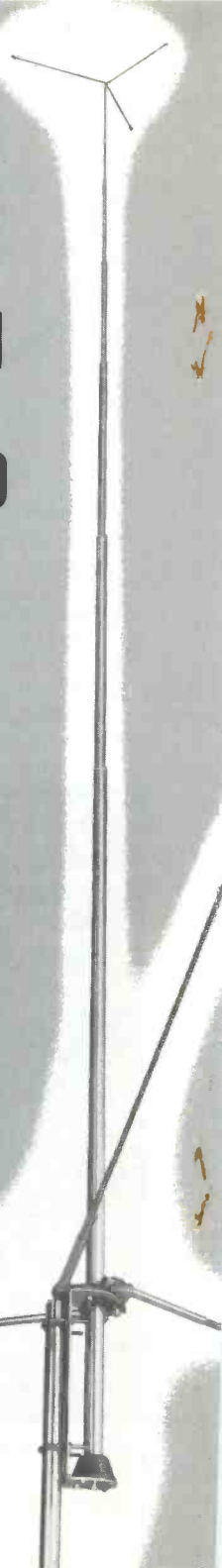

Hy-gain does it again

...the new improved

CLR II BASE STATION ANTENNA FOR CITIZENS BAND

- **8db Gain in All Directions**
- **Large Signal Capture Aperture**
- **Rugged Double Grip Mast Bracket**
- **Unique Static Arrestor**
- **Taper Swaged Seamless Aluminum Tubing**
- **Quickly and Easily Installed**

Here's the most efficient omni-directional base station antenna ever made for Citizens Band... Hy-Gain's Model CLR II. It's a complete re-design of the history-making CLR Colinear - the world's original gain base station antenna for Citizens Band. The CLR II combines Hy-Gain design and production ingenuity with the experience gained from over 60,000 CLR's now in use throughout the world to bring you the highest performance base station antenna made. Every significant electrical and mechanical innovation that has a justifiable application is incorporated in the new CLR II. How good is it? The CLR II is positively guaranteed to outperform any omni-directional base station antenna made for Citizens Band... regardless of claims. When can you get a CLR II? You can get it now from your favorite Hy-Gain Distributor. It's priced at only \$29.95 Net.

**COMPARATIVE PERFORMANCE CHARTS
CONCLUSIVELY DOCUMENT THE PERFORM-
ANCE SUPERIORITY OF HY-GAIN'S CLR II!**

Write for your copy today

HY-GAIN ANTENNA PRODUCTS CORP.

8467 NE HIGHWAY 6, LINCOLN, NEBRASKA

The World's Largest Manufacturer of Communications Antennas

NEW MECHANICAL SUPERIORITY

Structurally the CLR II is rugged. Every component part of the CLR II has been subjected to exhaustive and exacting laboratory and field testing to insure maximum durability.



RUGGED DOUBLE GRIP MAST BRACKET

A heavily ribbed, heavy gauge metal mast bracket binds the CLR II solidly to the mast. The 12" bracket provides two separate points of support to the bottom 12" of the radiator and the top 12" of the mast. Insures the CLR II will stand erect and secure at all times.

WEATHERABILITY

All metal parts are iridite treated to MIL specs. Molded high impact Poly-Styren insulators impregnated with tough, durable fiberglass are totally impervious to weather. Insulators are mounted under compression... never under strain.

TAPER SWAGED SEAMLESS ALUMINUM TUBING

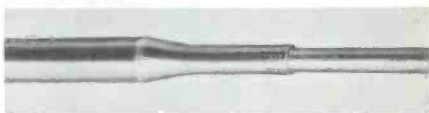

A new engineering design in tapering tubing that decreases wind load and gives added strength to the antenna. Strategically located swagings reduce the diameter of the tubing within inches as opposed to conventional gradual taper where comparable diameter reductions require several feet of linear distance. Reduced wind load allows CLR II to withstand gale-force winds.

INSTALLS QUICKLY

The CLR II is factory pre-assembled except for telescoping tubing. All tubing is factory pre-drilled and coded—no measuring required. Only minutes from carton to contact.

NEW ELECTRICAL SUPERIORITY—8db gain in all directions

Performance wise, the CLR II delivers an unparalleled 8db of omni-directional gain—DOUBLES THE EFFECTIVE RADIATED POWER OF THE ANTENNA.

3.4db OMNI-DIRECTIONAL GAIN

3.4db of omni-directional gain in measured field strength intensity is achieved through using maximum legal aperture (greatest possible signal capture area). By using maximum legal height for the radiator (19' 10"), the radiator is electrically extended to $\frac{3}{4}$ wave length. Full $\frac{1}{4}$ wave length (9') horizontal radials provide a ground plane system. The $\frac{3}{4}$ wave length radiator working against the $\frac{1}{4}$ wave length ground plane system produces the lowest possible angle of radiation and directs the maximum amount of energy along the horizon for greatest possible range.

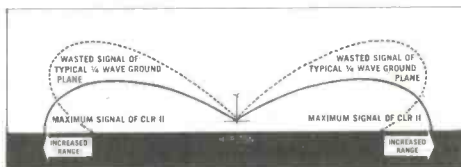

6db CIRCUIT GAIN

6db gain in improved signal-to-noise ratio is accomplished with Hy-Gain's unique built-in static arrester. Prevents static build-up and greatly reduces atmospheric noises in the receiver. Reduction in static build-up results in gains in signal-to-noise ratio of 6 to 20db. Additionally, the static arrester minimizes lightning hazard to the antenna and your equipment.



NEW SOLID STATE MATCHER

New moisture-proof Solid State Matcher is permanently weather protected. Recessed 52 ohm coax cable connector is imbedded in a moisture-safe housing to insure against electrical failure. SWR is less than 1.2:1.

carries a whisper
... yet cuts out
background noise



the exciting new **Hot Head**

The new Hot Head is the highest output ceramic microphone available. Transmits voice sharply and clearly in the noisiest areas where other microphones fail. Average level: -48 DB, twice the output of conventional ceramic mikes. Response: 300-4000 cps. Polar Pattern, differential to 600 cps; cardioid, 600-4000 cps. Covers a host of applications: CB, Ham, Radio, Marine and Commercial. Heavy duty, DBDT push-to-talk switch can be re-wired for special applications. Has Cylolac, hi-impact, take-apart case. With nickel-plated brass hardware, 3-conductor neoprene coil cord and spring hang-up clip. **Model C47D Hot Head** List Price **\$16.00**

EUPHONICS C47 MICROPHONE

A new general-purpose ceramic microphone, same as the C47D except for noise-cancelling feature. Polar Pattern, essentially non-directional. Provides high level response curve for maximum intelligibility in all voice communication.

Model C47 List Price
Hot Head **\$14.00**



See your distributor
for complete details or write

Euphonics CORPORATION
Dept. S-9
GUAYNABO, PUERTO RICO, U.S.A.

CB IN ACTION

By Len Haas,
Sales Manager,
Pearce-Simpson, KBG7527



Spring is here and a young man's fancy turns to thoughts of... CB. And a tough winter it was too! Tough on both men and equipment. Time for a long overdue Spring tune-up. Let's get the most out of your rig for a summer of fun and hard use. Here is a quick check that you can give your equipment to make sure that it is in top operating form.

1. Check the antenna at both the mobile and base stations for corrosion at the connector. Check all mechanical connections.
2. Check the transmitter tubes in the high level stages (the power amplifier and audio amplifier).
3. Check the receiver tubes.
4. Check the final amplifier in accordance with the tuning recommended in your service manual.

Now that you have checked out your equipment, let's make sure that you are tuned to the legal limit of 5 watts input.

In order to determine your input, check the plate current of the final amplifier by placing a 100 Ma meter in series with B plus to the plate of the final amplifier. Connect a volt meter to measure the plate voltage.

Now apply this formula:

$$P = E \times I$$

Where: P = Power in watts

E = Plate voltage in volts

I = Plate current in amps.

Example:

The plate current = .018 amps (18 Ma)

The voltage = 300 Volts D.C.

Then: $300 \times .018 = 5.4$ Watts

This is your input. This would be over the legal limit and you would have to decrease the loading of the final amplifier to .016 mls.

Checking your output is just as simple. Connect a pure resistive load across the antenna of the unit and an RF amp meter in series with it. Now use the formula $W = I^2R$

Where: I = Antenna current in Amps

R = Resistance of antenna

W = Watts

Example:

I = .2 amps

R = 52 ohms

Then: $(.2)^2 \times 52 = 2.08$ watts RF output to the antenna.

Incidentally—I want to thank all of you CB'ers who have sent me your QSL cards. I have a nice card display set up in my office. My own cards are being printed and should be out to you in a couple of weeks.

As you know our first "Companion" CB transmitter was awarded in our last column. Another "Companion" CB will be presented in October. So keep writing those "CB in Action" letters. Remember, just tell us how you or your club used CB to help serve your community. The winning letter will be publicized in our column and used to show the value of CB to those who are planning restrictive legislation.

Write to Len Haas, Sales Manager, Pearce Simpson, 2295 N.W. 14th Street, Miami 35, Florida.

Always say you saw it in 59



ELECTRONICS 'N STUFF

by DON STONER, 11W1507
BOX 7388
ALTA LOMA, CALIF.

A LOOK AT TRANSMISSION LINES

Sam peered into the variety of expressions in the audience assembled on work benches, scope carts and so forth in his See Bee Service Saloon. "From the questions and comments, I've been hearing this evening it sounds like you gents should absorb a few thousand carefully chosen words on transmission lines," he said. This was to be the subject of discussion for the monthly meeting of "The Foxy Fivers," the local CB club.

"Speech—speech," applauded several of the members, knowing very well what was coming.

Sam continued, ignoring his heckling friends. "You use terms like RG-58/U, coax, standing wave ratio, impedance and so on, but do you really understand what they mean?" He directed the question to no one in particular, but continued.

"The purpose of the device we call a transmission line is to deliver the r.f. power, generated by the transmitter, to the antenna. You might think of the transmission line as a *radio frequency hose* in which radio frequency signals flow rather than water. If we didn't have such a thing as a transmission line it would be necessary to mount the antenna right at the transmitter, or the other way around. This would certainly be disastrous for CB'ers. Take George over there. He's the only guy in this club who uses 200 feet of coax cable." Then he added under his breath "straight up."

"Most CB'ers use a type of transmission line called coax which is short for coaxial cable. It consists of a center wire with braid woven over insulation which separates the braid from the center wire. Braid is used to make the cable more flexible and easy to handle. The stuff can really take a lot of punishment. You can knot it, twist it, even slam the car door on it without the center wire shorting to the braid. Only excessive heat, which melts the insulation, will cause the cable to short. Not all transmission lines are like coax, however, sometimes open wire line is used (like television lead-in which is

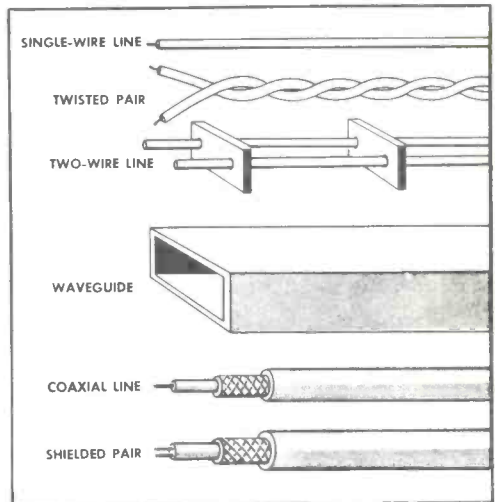

Transmission Lines

cheaper) and on the high frequencies (microwaves) the energy is sent to the antenna through hollow pipes called 'plumbing.'

"Our 'radio wave hose' does have one deficiency, however. All the water forced into a regular hose will come out the other end, assuming it doesn't have any leaks. This is not so with our radio frequency version, the transmission line. We always get less out one end than we put into the other end.

"This effect is called *loss*. The energy is lost forever in the form of heat. The amount of loss will depend on the type of cable used and, naturally, how long it is. The two types of coax commonly used by CB'ers carry the military specification number RG-8/U or RG-58/U. Type RG-8/U is considerably larger and is rated to carry 1,000 watts (one kilowatt) of power while the RG-8/U has noticeably less loss than RG-58/U and this is the reason for the higher power rating *not* the thicker insulation. The insulation of RG-8/U will withstand the very high voltage generated by an automobile ignition coil and can actually be used for shielded spark plug

Continued on page 51

PART 15 CALLBOOK

We will be keeping this on a constantly revolving basis, calling on each call area every few months to bring it up to date with the latest additions. If you subscribe to \$9 you will be assured of having a complete Part 15 callbook as we have no plans at present to issue these calls in one single volume.

Entire contents copyright 1963 by Cowan Publishing Corp.

PACIFIC		Ch			Ch
310-311 C. W. Eckhardt Jr., 209 E. 4th Ave.,	Ritzville, Wash.	2	240-242 D. Marquardt, 2028 E. 8th,	Spokane 32, Wash.	11
312 H. A. Wear, Rt. 2, Box 191A,	Grandview, Wash.	7	243-244 D. C. Stevens, 2200 Bush Ave.,	Olympia, Wash.	A,B
313-314 B. H. Benzel, 206 W. 8th,	Ritzville, Wash.	A	245 V. Hathaway, 1800 Airport Dr.,	Bakersfield, Calif.	1
315 C. S. Deacon, 5040th Box 2106,	APO 942, Seattle, Wash.	G	247-250 R. J. Hall, 13445 Close St.,	Whittier, Calif.	
316-321 C. Menger, 831 40th Ave.,	San Francisco 21, Calif.	7,9,11	251-255 K. Wong, 152 Wilson St.,	Albany, Calif.	5
322-324 C. Brown, 3609 Brooks Ave.,	Santa Rosa, Calif.	All	256-258 M. J. Debish, 8300 N. Oconto	Ave., Niles 48, Calif.	3
325 E. E. Wheeler, 729 W. Harris St.,	Eureka, Calif.	All	259 J. Heutmacher, 2744 S. W. 167th,	Seattle 66, Wash.	1
326-329 J. L. Hiers, P. O. T 3158,	Eureka, Calif.	All	260-261 W. Sempie, 1424 S. 103 St.,	Seattle 68, Wash.	2
330-331 D. Wong, 783 34th Ave.,	San Francisco 21, Calif.	7	262-263 N. Gumsler, 1411 S. 103 St.,	Seattle 66, Wash.	2
332-333 C. R. Pitts, 333 S. W. 1st St.,	Newport, Oreg.	11,7,22	264-265 T. L. Thompson, 1008 S. Miller	St., Wenatchee, Wash.	9
334-335 G. L. Schultz, 2829 Berg St.,	N. Las Vegas, Nev.		266-268 P. G. Griold, 16320 Ludlow St.,	Northridge, Calif.	
336-338 B. Gow, 3639 Balboa St.,	San Francisco 21, Calif.	1,5,7,9	269-271 P. E. Yarker, P. O. Box 252,	Rosalia, Wash.	7,11
339-340 J. S. Sudduth, 8103 16th S. W.,	Seattle, Wash.	12	272 E. Cobb, Box 137, 5040 Civil Engr.	Group, Seattle, Wash.	
341-342 J. G. Hendrick, Rt. 1, Box 259,	Silverdale, Wash.	F	273-276 L. Cobb, 2810 Pope Ave.,	Apt. C, Sacramento 21, Calif.	4
343-346 L. G. Myers, Box 293-B, Rt. 3,	Olympia, Wash.	F	277-278 B. Scamell, 429 Olive St.,	Vallejo, Calif.	9
347-348 R. L. Anderson, P. O. Box,	Winlock, Wash.	11	279-280 B. E. Lindsey, 429 Olive St.,	Vallejo, Calif.	4
349-351 G. E. Williams, 235 E. Mendocino	Ave., Stockton, Calif.	11,18	281-284 C. M. Stramaglia, 18208 Judy St.,	Castro Valley, Calif.	A,B
352-353 M. Lonergan, 631 Cedar Ave.,	Richland, Wash.	7	286-287 R. S. Rooks, Box 717, White	Salmon, Wash.	
354 K. Jones, Rt. #3, Bryant Ave.,	Walla Walla, Wash.	7	288 R. Schwartz, 1125 N. E. Craft St.,	Newport, Oreg.	4,7,11
355 K. Jones, Rt. 3, Bryant Ave.,	Walla Walla, Wash.	7	289-290 E. Neville, 210 S. 34th St.,	Billings, Mont.	8
356-357 R. Brosey, Box 26, Winlock,	Wash.	7	291-292 J. L. Nelson, 1053 Beach St.,	Marysville, Wash.	7
T. Mice, 140 Latherwood Ave.	Redwood City, Calif.	B	293-294 A. French, Rt. 1, Box 213,	Tieton, Wash.	
359-362 R. Forsberg, 411 E. Fernfield	Dr., Monterey Park, Calif.	7	295-296 C. A. Porter, 2310 University	Ave., Bakersfield, Calif.	17
363-364 C. E. Harmon, 1639 Arvilla	Dr., Sacramento 22, Calif.	9,C	298-299 E. P. Cushing, Box 827,	Sparks, Nevada	2
		A,H	300-301 C. Hanks, 4222 S. E. Adams	St., Milwaukie 22, Oreg.	11
365 R. Kinley, Box 832, Watsonville,	Calif.	4	302-303 R. M. King, 3301 Holly Dr.,	Sacramento 25, Calif.	1,2
366-368 C. G. Vallquist, Rt. 1, Box 325,	Anacortes, Wash.	7	304-305 R. J. Larson, 211 S. W. 4th	St., Newport, Oreg.	14,11,2
369-370 R. J. Borchering, 8706 N. W. 9th	Ave., Vancouver, Wash.	4	306-309 J. Stricker, 215-1/2 S. 28th	St., Billings, Mont.	4
371-373 L. Fabisch, 3650 Balboa St.,	San Francisco 21, Calif.	10	SOUTHERN		
374-375 J. Paulbiek, 2200 Pardee,	Las Vegas, Nev.	A,B,H	119-122 H. T. Prunty, 3080 Lakeview	Road, Shreveport, La.	A,H,B
376-377 H. Collier Jr., 1025 2nd,	Bakersfield, Calif.	All	123-126 J. L. Prunty, 1761 Caroline St.,	Shreveport, La.	A,B,H
378-381 R. W. Patterson, Box 11, 719	18th St., Oroville, Wash.	8,10,15	127-131 J. W. Younger, P. O. Box 283,	Sarasota, Fla.	
383-385 E. W. Fassett Jr., 1451 146 Ave.,	San Leandro, Calif.	22	132-133 E. L. Keinert, 1128 N. E. 17	Terrace, Fort Lauderdale, Fla.	A,D
386-387 J. F. Long, P. O. Box 216,	Lynnwood, Wash.	9	134-138 P. J. Anderson, 6660 10th	Ave. Terr. So., St. Petersburg 7, Fla.	All
388-389 G. D. Schultz, Rt. 2, Box 494,	Marysville, Wash.	11	139-140 R. W. Huff, Gen. Del.,	Kingsland, Ark.	B
390-391 M. K. Reeves, 1223 N. E. 105th	St., Seattle, Wash.	B	141-144 A. G. Secret, 1325 46 Ave.,	Meridian, Miss.	
392 E. F. Massarre, 131 14th Ave.,	San Francisco 18, Calif.	F	145-146 D. W. Lowe, 14 Valley Dr.,	Little Rock, Ark.	14
393-394 P. J. Abernathy, 2415 Fairfield	St., Eureka, Calif.	A	147-148 J. E. McCoy, 248 Briarwood	Dr., Jackson 6, Miss.	
395 R. Haskell, 1421 Union St.,	Alameda, Calif.	A,B,D	149 T. Byers, 1710 Lake Park Dr.,	Laurel, Miss.	
396-397 E. W. Haskell, 1421 Union St.,	Alameda, Calif.	A,B,D	150-152 G. M. Meisner, 1307 Matilda	St., West Lake, La.	
398-400 F. Robinson, P. O. Box 20,	Everett, Wash.	15,22	153-154 F. E. Henderson, 505 N. Walker	St., Plant City, Fla.	A
401 L. Haskell, 1421 Union St.,	Alameda, Calif.	A,B,D	155-157 C. D. Bartholomew, 40 W. Dixie	Highway, Dania, Fla.	
402-403 D. V. Bashaw, 5125 S. E. Malden	Dr., Portland 6, Oreg.	11	158-161 D. T. Jackson, 107 Orange	St., Auburndale, Fla.	7
404-405 V. Kee, 512 Bond, Astoria,	Oreg.	11	162 J. Sanders, P. O. Drawer A,	Laurel 4, Miss.	
406-407 P. A. Franzwa, 418 7th St.,	Lake Oswego, Oreg.		163-164 R. F. Hedman, 516 Cherry	Rd., West Palm Beach, Fla.	A,9
408-409 M. E. Walton, 1314 Park Ave.,	Inglewood, Calif.	10	165-166 H. Leondanner, 803 W. Ricken	backer Dr., Midwest City, Okla.	
410-412 J. Owens, 2103 12th Ave.,	Oakland 6, Calif.	A,B	167-168 J. W. Cochran Jr., 204 W. Marshall	Dr., Midwest City, Okla.	
413-415 L. D. Anderson, 8011 Ferguson	Dr., Los Angeles, Calif.	9	169-170 J. H. Atwood, 4334 Broussard	St., Baton Rouge, La.	A
416 J. Willott, 2017 Cayon Rd.,	Arcadia, Calif.	All	171-173 G. Kelley, Box 1166 (521 S. W. 15th	Ave.), Boynton Beach, Fla.	9
417-419 S. W. Chism Jr., 1747 81st	Ave., Oakland 21, Calif.	A	174-176 A. G. Cocco Jr., 502 S. Moody	Ave., Tampa, Fla.	
420-423 J. W. Mosby, 228 Willow	Rd., Menlo Park, Calif.	4	177-181 R. L. Walker, 3402 S. School	Ave., (S. Gate), Sarasota, Fla.	A,B,H
424-428 C. Woodriddle, 741 Toyon	Dr., Monterey, Calif.	15	182-183 B. Warren, 712 Nebraska	Ave., Weslaco, Texas	9,11
188-189 G. Decker, 2009 1st, La	Grande, Oregon	10	184-185 N. G. Blitch, 2116 Post St.,	Jacksonville 4, Fla.	5-F
190-191 D. Hoims, 1201 W. La	Grande, Oregon	7,9	186-189 J. L. Nall, Route 1, Box 354,	Houghton, La.	A,B,H
192-193 G. Cunningham, P. O. Box	372, La Grande, Oregon	4	190-192 R. E. Stiles, 534 W. 76 St.,	Shreveport, La.	A,B,H
194-195 D. Young, Rt. 1, Box 264,	La Grande, Oregon	11	193-200 H. H. Teeter, 1115 Trigg,	Amario, Texas	A,C
196-198 J. L. Jensen, Rt. 1, Box 426,	La Grande, Oregon	7	201-202 J. R. Johnson, 508 Clearmont,	El Dorado, Arkansas	All
199-200 E. W. Bush, 12615 Occidental	S., Seattle, Wash.	9	203 L. C. Fennell, 144-20 Ave. North	St., Petersburg 4, Fla.	9,10
201-202 F. H. Bush, 10054 S. E. 7th,	Bellevue, Wash.	9	204-205 J. Hill, 837 S. Shores	Rd., Jacksonville 7, Fla.	10
203-205 T. D. Sparley, 1929 W. 5th,	Kennewick, Wash.	A,B,C,D	206-207 E. A. Heggen, 139 Lafayette	Circle, Ocean Springs, Mississippi	13
206-209 W. F. Brooks, Jr., 1924 Evergreen	Ave., Washington, Wash.	A	208-211 R. A. Frings, 1806 Efic	Lane, Pasadena, Texas	A,C,10,11
210-211 W. Stromer, Rt. 1, Madden	Rd., Live Oak, Calif.	99	212-213 J. D. Buffington, 115 Highland	Ave., Averdeen, Mississippi	11
212-213 D. Purdy, 1027 S. W. 124,	Seattle, Wash.	9	214-216 A. G. Harvey, 369 Magnolia	Place De Bary, P. O. Box 461, De Bary, Fla.	1
214-215 N. Edwards, 15810-8 S. W.,	Seattle, Wash.	9			
216-217 V. Monson, Rt. 2, Box 49,	Govan, Wash.	11			
218-219 J. R. Edmunds, Rt. 5, Box	5019, Wenatchee, Washington	A thru H			
220 J. Ensminger, 1323 Exley, Las	Vegas, Nevada	A			
221-222 O. L. Pellett, 2102 1/2 FIR,	La Grande, Oregon	10			
223-227 R. Breshers, R. F. D. Alciel,	Alciel, Oregon	13			
228 R. Cheney, 2012 Airport Dr.,	Bakersfield, Calif.	C			
229-230 H. O. Fields, 4809 Parker	Ave., Sacramento, Calif.	A,H			
231-236 W. G. Toland, 616 Lincoln	Rd., Stockton, Calif.	5,7,11			
237 J. E. Lough, 6124 N. E. 25th	Ave., Oregon	A,16			
238-239 C. D. Peavy, 4523 S. E. Jackson	St., Milwaukie 22, Oreg.	A,D			

This is the

NUVISTAPLUG

The NUVISTAPLUG is a highly effective nuvistor amplifier designed as an exact replacement for the present rf amplifier tube in most communications receivers.

The NUVISTAPLUG will replace 7 pin miniature pentodes only. It will operate in almost 80% of all receivers using a 7 pin miniature pentode as the rf amplifier, reducing the noise level quite noticeably, and thus making weak signals pop out above the noise level.

The NUVISTAPLUG is sold on a money-back guarantee in the event that it doesn't improve your particular receiver. More than 2,000 Nuvistaplugs are currently in operation, and the manufacturing facilities have been stepped up heavily.

NUVISTAPLUGS are now available in large quantity for immediate delivery. Be certain to specify exactly which model is desired. Don't delay! Your receiver most likely will be greatly improved by adding a NUVISTAPLUG. You'll never know unless you try it.

ONLY \$19.95

postpaid
(No C.O.D.'s)

RAYTRONICS

Post Office Box 672
Times Square Station
New York 36, New York

N.Y.C. Residents add 4% City Sales Tax

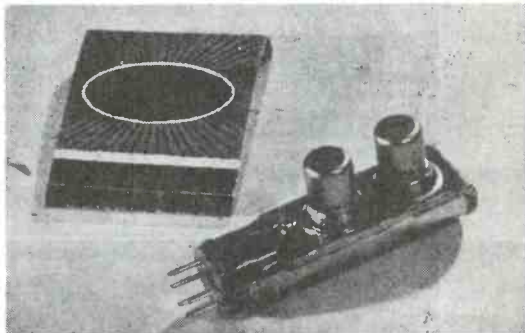

Read Len Haas' Column "CB In Action," PAGE 30



IN ACTION!

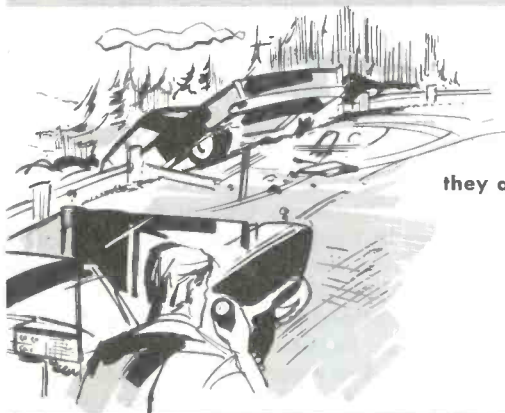

10-33, Mayday

or

S.O.S.

they all mean the same thing . . . an emergency.

And this is when CB really swings into action.

There is no civic group in this country that can claim a better record of helping when it counts, than CB'ers and their clubs.

Whether it be rescuing a distressed motorist, helping the police locate lost persons, or aiding the injured, CB is on the spot — and "In Action" around the clock.

"Sound" Reasons for Buying the "Companion"

- Channels—5, plus front panel crystal socket for use on any channel.
- Transistorized Power Supply—5 watts input, 3 watts into 50 ohms output.
- Adjustable squelch control. Modulation—high level limited to 95%.
- Pre-set automatic noise limiter, gated squelch.
- Ultra-sensitive Super-het receiver — 1/2 microvolt.

See your authorized Pearce-Simpson dealer or write us for his name.



"Companion" Citizens Band Transceiver

PEARCE PS SIMPSON

PEARCE-SIMPSON
INC.

2295 N.W. 14th STREET
MIAMI 35, FLORIDA

CARD SWAPPERS UNLIMITED

SWAPPERS' AWARDS ANNOUNCED THIS MONTH!

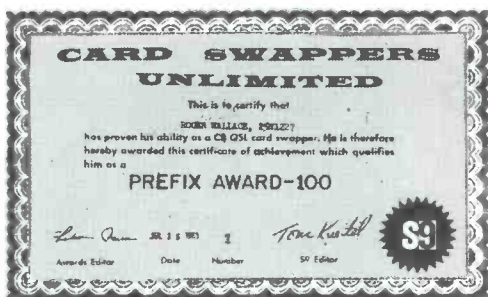

Well now, there are quite a few more card swappers kicking around than anyone had imagined. The group really came out in full force this month and gave our mailbox quite a stuffing. As promised, we are going full speed ahead with our swappers' awards to meet the demand of our readers. Here are the awards you swappers can win this month and from here on in:

SWAPPED ALL CALL AREAS AWARD "SACA"—Awarded upon proof of having swapped CB QSL cards with stations in all 24 CB call areas in the United States.

PREFIX AWARDS "PX-25," "PX-50," "PX-75," "PX-100"—Four separate awards given upon proof of having swapped CB QSL cards with 25, 50, 75, and 100 prefixes respectively. Canadian GRS and Part 15 cards are acceptable. Different prefixes assigned to one call area count separately, for example, 18A, 18B, 18Q, 18QA, 18W, KHA and KHC would count as 7 prefixes.

MASTER SWAPPER AWARD "MSA"—Awarded upon proof of having swapped CB QSL cards with 50 states, Puerto Rico, District of Columbia, all Canadian provinces.

SUPREME SWAPPER CLUB "SSC-1," "SSC-2," "SSC-3," "SSC-4," "SSC-5"—Five awards for having swapped CB QSL cards with 1,000, 2,000, 3,000, 4,000 and 5,000 stations, respectively. Foreign cards, as well as Part 15 cards are acceptable.

The rules and general information on the awards is as follows:

1. Cards received for actual 2-way contact with distant stations are *not* eligible because of the fact that such communications

are illegal. Cards received from stations who have monitored your signals (but with whom you did not engage in communications) are *not* acceptable. Handmade cards are acceptable only if they are postmarked from the location of the station being counted, or are contained in an envelope so post-marked.

2. Do *not* send us your CB QSL card collection when applying for an award. To apply for an award, simply list the call signs and locations of each station you are counting. Submit this, together with your full name, address, call sign, and the name of the award for which you are applying. Your

list may be on any type of paper, however it *must* be countersigned by another licensed CB'er who certifies that he (or she) has actually seen the cards in question in your permanent possession. We reserve the right, in certain instances, to request that applicants send us several specific cards for verification purposes prior to issuance of an award. Such cards will be returned immediately.

3. Enclose 50¢ (no stamps) for each award being applied for. You may apply for as many awards as you can qualify, including awards of lesser magnitude (that is, if you qualify for PX-75, you may also receive PX-25 and PX-50 if you wish. Requests for duplicate or extra copies of a

certificate should be accompanied by 25¢ for each.

4. Persons receiving swappers' awards will be listed in the next available issue of S9 after the issuance of the award(s).

5. All awards are attractively designed in 3 colors and are suitable for framing.

6. Additional awards for advanced achievements may be added at a later date. You are urged to list your awards when printing your next supply of CB QSL cards.

7. Additional copies of the award requirements and these rules are available from S9 at no cost. Please enclose a self-addressed stamped envelope.

8. All applications for awards *must* be addressed as follows: Swappers' Awards, S9 Magazine, 300 West 43rd Street, New York 36, N. Y.

From the mail we now are receiving, it looks as though many of you are ready for a few of these awards. For instance, S9'er Dan Guthrei, KDB1435, of Spruce Pine, N. C. has almost 1800 cards. He has all states (except Alaska), all of the provinces of Canada, Venezuela, San Salvador, Puerto Rico, England, Ireland, North Wales, and the District of Columbia. Dan is only one card away from his "MSA" award. He told us that his name appearing in our May issue brought him a huge avalanche of cards within a few days of the magazine's issuance. Ted and Rena Cummings, KBA5557, of Billerica, Mass. are only 6 cards away from 50 states. Dottie Burdette, KBA6639, of Cambridge, Mass., has all 50 states, D.C., P.R., Guam, Canada, and Venezuela. Jay Ciampi, KDH1144, of Miami, Fla., also reports "terrific" results from his name being listed in our May issue.

Wanna swap CB QSL cards? If you want one of our S9 cards, just send us yours and ask for one of ours! If you want to swap with other CB'ers, send us your card (no letters, please) addressed to "Card Swappers Unlimited" at the magazine's address. You must send in a separate card for each month you wish to be listed, and you can list yourself each and every month if you want. Cards submitted for listing in the September issue must be in our office not later than July 15th.

Here's the gang of swappers for this month:

Write to our advertisers for special product news

- 1Q0191 Murray Shlager, 42 Dorothy, Newton Center 59, Mass.
- 1Q0407 Gerard Lemire, 59 Summer, Berlin, N. H.
- 1Q5981 Edmund Gould, R.D. 3, Brandon, Vt.
- 1Q7090 Joe Thibodeau, Box 36, Fairfield, Me.
- 1Q5295 John Hart, 9 Carlton Terr., Lynn, Mass.
- 1Q7108 Don Sargent, 18 Lafayette Park, Lynn, Mass.
- 1W8636 Gordon Taylor, 14 Morgan Ave., Newbury, Mass.
- 2Q1911 William Plog, 11 Gould, Centereach, N.Y.
- 2Q2324 Harry Sauer, 84 Mill Rd., Latham, N.Y.
- 2Q4010 Val J. Auerbach, 646 S. 20th, Newark, N.J.
- 2Q4513 Jim Colaneri, 28 Northern Dr., Troy, N.Y.
- 2Q4813 Elsie Leonard, Ridge Rd., Hannacroix, N.Y.
- 2Q5500 Lillian Aoes, 12 Vermont, Sherwood Pk., Rensselaer, NY
- 2Q7376 Mickey Auerbach, 646 S. 20th, Newark, N.J.
- 2W4586 John Krejc, 40 Lanza, Garfield, N.J.
- 3Q1654 William Moore, Middletown, Del.
- 3Q2539 Bud Becker, R.D. 4, Hanover, Pa.
- 3Q2542 Bob Diehl, 240 York, Hanover, Pa.
- 4Q0547 Dick Linton, R.D. 2, Smithsburg, Md.
- 5Q0577 Fred Harris, Rt. 3, Gate City, Va.
- 5Q1221 Willard Davis, 1508 Grace, Lynchburg, Va.
- 5Q3755 Floyd Backus, 2906 Dellrose, Richmond, Va.
- 5W2108 Allon Clarke, 1009 Hamilton, Clifton Forge, Va.
- 6Q6745 Lewis Mize, Box 347, Gainesboro, Tenn.
- 6W6707 Chuck Dougherty, 42 Vanderhorst, Charleston, S.C.
- 6W7515 Terrell Craven, Rt. 1 Box 32, Royston, Ga.
- 1Q01587 A. W. Berg, 1710 N. Sapulpa, Oklahoma City 7, Okla.
- 11Q0153 L. C. Percy, 6371 San Marino Circle, Buena Park, Calif.
- 11Q5523 Warren Stolle, 534 W. Lexington, Glendale, Calif.
- 12Q1187 Bob Rames, 635 38th Ave., San Francisco, Calif.
- 12Q2285 Arlie Burleson, 15 RoseAnne Ave., Pittsburg, Calif.
- 12W5127 Marty Lydon, 4251 Annette, Sacramento 21, Calif.
- 15Q0555 Doug Anthony, Douglas, Wyoming
- 16Q2299 Dick Becker, 618 Elfelt, St. Paul 3, Minn.
- 17W3708 Raymond Mashek, Box 302, Troy, Mo.
- 18Q4862 Gay Dolin, Rural Rt. 2, Sullivan, Mo.
- 18Q2861 Ron Wilkinson, 246 W. 19th, Alton, Ill.

QSL'S by GARTH
Nation's Largest
From \$2.50 per 100 in 3 Colors
Free Samples & Catalog
Garth Printing Co. Jutland, N. J.

FREE

1 1/4 pin-back button! Send your call & complete address together with 25¢ for postage & handling. We'll also send our free goodies-list.

**HAVE
CARDS
WILL
SWAP**

Errol Engraving, Dept. 75
36 Hampden St., Westfield, Mass.

- 18B3503 John Wuest, 2005 Strathmoore, Louisville 5, Ky.
- 18Q2631 William Ferbrache, 824 Homestead, La Grange Pk., Ill.
- 18Q6396 Mike Gulliver, 112 Oriole Tr., Michigan City, Ind.
- 18Q6589 Al Haseman, 727 Woodward, Beecher, Ill.
- 18Q8866 Richard Carry, Rt. #2, Box 85, Ponthill, Ky.
- 18Q40830 Jim English, P.O. 434, Daleville, Ind.
- 19A5006 Doris Wesser, Presque Isle, Mich.
- 19A6512 V. D. Edwards, 100 Union Ave., Pomeroy, Ohio
- 19Q1001 Tim Hamilton, Rt. 3, Box 301, Wooster, Ohio
- 19Q3898 Bob Porter, R.R. 3, Ludington, Mich.
- 19Q5043 Ammon Coffman, 525 Hamilton, Bellefontaine, Ohio
- 19Q5534 Dick Knight, Rt. 2, West Union, W. Va.
- 19Q8014 Clare Griffin, 394 Oak, Britton, Mich.
- 19Q9014 David Reed, 546 Pond Run Rd., Raceland, Key.
- 19Q9470 Adrian Fallert, 121 North C, Hamilton, Ohio
- 19QA0412 Art DeFrain, 226 S. 3rd, Harbor Beach, Mich.
- 20Q3126 Harold Beachoff, RD 2, Greencastle, Pa.
- KBA0094 Rob Bergstroms, 1384 Jenness, Lynn, Mass.
- KBA1328 Ed Kupchunas, 28 Wood St., Nashua, N.H.
- KBA1707 Ted Singleton, 79 Lillian E., Bristol, Conn.
- KBA2614 Clifton Smith, Box 303, Block Island, R.I.
- KBA2979 Bernard Bastura, 440 Washington, Middletown, Conn.
- KBA4663 Guy Larken, Lincoln Rd., Saco, Maine.
- KBA4754 Gordon Stover, 24 Park, Houlton, Me.
- KBA5557 Ted Cummings, Bellflower Rd., Billerica, Mass.
- KBA6639 Dottie Burdette, 285 Brookline, Cambridge, Mass.
- KBA6744 Richard Pelouquin, P. O. Box 626, Berlin, N. H.
- KBA7107 Bill Reid, 35 Nahum Dr., Hartford 12, Conn.
- KBA8054 Ernie Risch Jr., 191 Great Neck, Waterford, Conn.
- KBA8091 Polly Huntington, R.F.D. Box 56, Topsham, Me.
- KBA8157 Norman Slachetka, 518 Chicopee, Williamssett, Mass.
- KBA8175 Manuel Rodriguez Jr., 25 Floyd, Lowell, Mass.
- KBA8553 Bill Jones, 127 Grove, Putnam, Conn.
- KBA8556 Lewis Young, 185 Southworth, Brockton, Mass.
- KBA8595 Lee Aspinall, 29 Forest, North Haven, Conn.
- KBA8619 Doug Fleury, 110 High, Lowell, Mass.
- KBA8638 Swede Hanson, 10 Greenwood, Malden, Mass.
- KBA8868 Bill Anderson, 11 Essex, Lynn, Mass.
- KBA8939 Bill Fleury, 52 W. Fourth, Lowell, Mass.

Continued

KBA9442 Roland Gosselin, 81 Wight St., Berlin, N.H.
KBA9566 Skip Hayden, Rt. 1, Box 300A, Easthampton, Mass.
KBA9654 Herb Anderson, 11 Essex, Lynn, Mass.
KBA9815 Mike Polission, 1029 Washington, Gloucester, Mass.
KBC0664 Blaise Sanzone, 20 Neenan Lane, Orange, Conn.
KBC1006 Ronnie Loeser, 46 Wesmur, Malden, Mass.
KBC0376 John E. Trombly, 32 Pages Court, Billerica, Mass.
KBC1748 Dave Levernoch, P.O. Box 145, Becket, Mass.
KBC1756 John Trudeau, 1088 South, Dalton, Mass.
KBC2224 Paul Margolis, 8 Gilman, Worcester, Mass.
KBC2689 Carl MacConnell, 23 Point Sunlight Rd., N.Billerica, Mass.
KBC2771 Clyde Albee, 245 South Main, Garner, Mass.
KBG1130 John Flynt, 3441 Jackson, Wantagh, L.I., N.Y.
KBG2773 Pearl Shaddick, R.F.D. 1, Ft. Ferry Rd., Cohoes, N.Y.
KBG4290 Steve Smith, 211 Magnolia, Mt. Vernon, N.Y.
KBG4303 Tom Kneattel, 300 West 43rd, New York 36, N.Y.
KBG4549 Clifford Conti, 24 Schuler, Waldwick, N.J.
KBG4657 Fred Wutrich, 64 Camp, Sidney, N.Y.
KBG7650 Norman Avery, 400-24 Shiswell Rd., Schenectady, N.Y.
KBG8537 Bill Wheaton, 270 William, Hillside 5, N.J.
KBG8649 Bob Ishkanian, 270 E. Shore Dr., Massapequa, N.Y.
KBG9852 Margie Albertson, 2 Boulevards, Sea Cliff, L.I., N.Y.
KBG9233 Dale Fraser, 143 Five Grove, Kings, N.Y.
KB11950 Skip Stamberger, 335 Carmia, Rutherford, N.J.
KB11875 Skip Barker, 162 Kemah, Ridgewood, N.J.
KB13142 Jesse Hellman, 2564 E. 11th, Brooklyn, N.Y.
KB13248 Jack Spitz, 3255 Shore Pkwy., Brooklyn, N.Y.
KCC1541 Donald Berle, 228 California, Quakertown, Pa.
KCC1694 Joseph Bologes, 421 Atlantic, Bethlehem, Pa.
KCC2998 Frank Denney, 212 Forwood, Chester, Pa.
KCC3650 Ben Mosteller, 38 Walnut, Phoenixville, Pa.
KCC3847 Skip Tuma, 1452 N. 59th, Philadelphia 31, Pa.
KCC3960 Josef Murray, R.F.D. 2, Cape Mt. C. H., N.J.
KCD0117 Albert Friedrich, 421 E. 24th, N. Wildwood, N.J.
KCD0243 Ervin Zartman Jr., R.D. 2, Spring Grove, Pa.
KCD1205 Anthony Mattia, 258 N. Simpson, Philadelphia 39, Pa.
KCD1641 Jeanette Rogers, 2033 Opel, Boothwyn, Pa.
KCC9986 Richard Long, 711 N. Mechanic, Cumberland, Md.
KCF1170 Al Ebel, 1803 Tucker, Mc Lean, Va.
KCF2762 Robert Gallery, 4424 Montgomery, Bethesda, Md.
KCG0107 Jacob Weiss, 1005 Mace, Essex 21, Md.
KCG0228 Willard Casto, Box 36, French Creek, W. Va.
KCG0299 Gene Ray, Rt. 2, Box 354, Morgantown, W. Va.
KCG0774 Lew Reinberg, 4118 Katland, Baltimore 7, Md.
KCI0348 W. C. Hatcher, 713 Parrott, Kingston, N.C.
KCI1041 Robert L. Sydnor, Amelia, Va.
KCI4490 Al Wood, 3204 Cahill, Lynchburg, Va.
KCI6095 George Cline, 1530 Grove, Palmyra, Va.
KCJ0327 John Deweese, 343 Deaner, N.W., Roanoke, Va.
KCJ4047 Glenwood Spence, Rt. 3, Goldsboro, N.C.
KCJ0560 Jim Green, 2603 Maplewood, Richmond 28, Va.
KCJ1022 Ray Sturgill, 2111 3rd, Big Stone Gap, Va.
KCJ1425 Robert Gagnon, 1408 Fullview, Mechanicsville, Va.
KCJ1560 Hazel Robbins, 140 Wentworth, N.E., Roanoke, Va.
KDB0217 David Johnson, Rt. 1, Cedar town, Ga.
KDB0371 Bill Howell Jr., 545 Palmetto Lane S.W., Alken, S.C.
KDB1114 Herman Flinkingshelt Jr., 8 Callahan, Greenville, S.C.
KDB1435 Daniel Guthrie, Box 362, Spruce Pine, N.C.
KDB1807 James Garlgues, Box 481, Glencoe, Ala.
KDB2460 Joe Johnson, 221 Houseal, Cedartown, Ga.
KDB3334 James Robinson, Rt. 2, Rockmart, Ga.
KDB3389 Wesley Liles, 715 Jackson Blvd. Tarrant, Bmghn 7 Ala.
KDB3573 John Carolina, Kingsport, Tenn.
KDB3715 Emmett Griffin, 228 Busha, Toocosa, Ga.
KDB4842 Troy Kenemer, Rocky Face, Ga.
KDB6783 Jim Case, 913 E. Washington, Athens, Ala.
KDB7184 John Bryant Sr., 1711 Gibson, Montgomery 10, Ala.
KDB7747 Bill Frankenfield, Tryon, N.C.
KDB7891 Walter Baird, Rt. 3, Box 443, Florence, S.C.
KDB9144 Gilbert Black, 2224 Bide-A-Wee Dr. NE, Huntsville, Ala.
KED00748 Mike Jones, 1 Rollingwood, Aiken, S.C.
KDD1232 George Baines, Rt. 1, Aragon, Ga.
KDD1568 Joe Lee, P.O. Box 521, Lancaster, S.C.
KDD3487 Kenneth Gwinn, R.F.D. 2, Woodruff, S.C.
KDH1144 Jay Ciampi, 17700 S.W. 111th, Miami 57, Fla.
KDH2128 Wallace Antley, 5347 Jennings Circle, El Paso, Texas
KDH2523 Joe Yglesias, P.O. Box 6353, Tampa 5, Fla.
KDG2671 Ernest Howell, 306 S. 18th, Fernandina Beach, Fla.
KED0447 Thomas Holliger, Box 216, Almyra, Ark.
KED0707 Jerry Knepper, 1507 Austin Highway, San Antonio, Tex.
KED1423 Fred Huttner, 5415 N. New Braunfels, San Antonio, Texas
KEG0660 Bill Dobsch, 1435 Rosan, Dallas, Texas
KEG0782 James McWain, 807 N. East, Arlington, Texas
KEG2334 C. E. Kuelin, Box 265, Meridian, Texas
KEH0829 Billy Suth, P. O. Box 234, Atoka, Okla.
KEH1005 Ann Antley, 5347 Jennings Circle, El Paso, Texas
KEH3890 Ted Pauline Green, Box 17, Cuyama, Calif.
KFA2078 John Polson, 946 So. Lake, Los Angeles, Calif.
KFC0550 Cecil Brown, 3609 Brooks, Santa Rosa, Calif.
KFJ1392 George Thompson, San Luis Obispo, Calif.
KEJ7120 Kenny French, 13661 Judd, Pacoima, Calif.
KFA0433 Ray Pollok, 2458 Zorada, Hollywood 46, Calif.
KFC2921 Bill Seale, 429 Old Valley, Calif.
KFC3136 Rose Gosnell, P.O. Box 1094, San Francisco 1, Calif.
KFC3163 Marvin Switzer, Rt. 1, Box 107, Wheatland, Calif.
KFC3415 Doug Parker, 3015 Justus, Soquel, Calif.
KFC3527 Steve Herberth, 36 Raymond, Reno, Nev.
KFC3693 Shirley Woodall, 610 Modesto, Santa Cruz, Calif.
KFC3808 Val Golding, P.O. Box 1094, San Francisco 1, Calif.
KFD0102 Chuck Woodbridge, 741 Toyon, Monterey, Calif.
KFI1339 Phil Hawkins, 558 Prindle, Chehalis, Wash.
KFJ0200 F. Robinson, P.O. Box 20, Everett, Wash.
KG00032 U. S. Anthony, Douglas, Wyoming
KG11159 Ben Messersmith, 864 Liberty, Ogden, Utah
KG18721 Bob DeVito, 356 Schenectady, Schenectady, N. Y.
KG0682 Frank Radzinski, P.O. Box 147, Rhinelander, Wis.
KG02536 Frank Brown, 407 St. Anthony St. Paul 3, Minn.

KGE2634 Wesley Jones Sr., 970 E. Jessamine, St. Paul, Minn.
KG0109 John LaFond, 3302 22nd Ave., Rochester, Minn.
KG0272 Wesley Jones Jr., 407 Compton, St. Paul, Minn.
KG06559 David Radzinski, Box 147, Rhinelander, Wis.
KGH0156 Leslie Doss, 307 Linda Lane, Wentzville, Mo.
KGH0550 Ward Donnel, 1018 W. Central, Carthage, Mo.
KGH1152 Marvin Kreisman, Box 882, Columbia, Mo.
KGH4430 LaTray Mobeley, 8126 Frost, Berkeley 34, Mo.
KGH4846 John Funk, 4817 W. 17th, Topeka, Kansas
KGH5667 James Girault, 160 Campbell Ct., Troy, Mo.
KHA1377 John Wirag, 1845 W. Oakdale, Chicago, Ill.
KHA2907 Jim Cassidy, R.R. 2, Rantoul, Ill.
KHA2962 Raymond L. Cline, 516 Springdale Dr., Elizabethtown, Ky.
HD47859 Bonnie McGrew, LeClaire, Iowa
KHA9921 Tom Hansen, 2nd Ave., RD, Clinton, Iowa
KHB0148 Al Maglinger, 1330 Rose Hill, Owensboro, Ky.
KHB2363 Karlton Luft, 1127 Arthur, Oshkosh, Wis.
KHB3803 Roger Tesch, 445 N. Lake, Aurora, Ill.
KHB3971 Larry Parkhurst, R.R. 1, Columbia City, Ind.
KHC1006 James Miller, 2704 Pine, Mattoon, Ill.
KHC1466 Gene Swearingen, 2501 Richmond, Mattoon, Ill.
KHC1607 Jim Cole, 830 N. 16th, Elwood, Ind.
KHC2157 Wayne Oehler, 10821 W. Cameron, Milwaukee 18, Wisc.
KHC3155 Rich Heiden, 1042 W. Prairie, Decatur, Ill.
KHC3315 Jack Magers, 403 W. Water, Hartford, City, Ind.
KHC5371 Beth Cole, 830 No. 16th, Elwood, Ind.
KHG0850 Andrew Arison, Box 386, Spencer, W. Va.
KGH0540 Dave Morrison, 63 E. College, Alliance, Ohio
KHG7213 John Oswald, 1322 Lander Rd., Mayfield Heights, Ohio
KHG7856 Kurt Kammann, 14423 Faircrest, Detroit 5, Mich.
KHG8931 Bill Kline, R.R. 2, Caledonia, Ohio
KHH0396 Bob Kienel, 443 Wapaknetta, Ohio
KHH0407 Jerry Rathburn, 222 W. Main, Alexandria, Ohio
KHH0825 Bob Wolfe, 1614 Lyons, Lansing, Mich.
KHH0880 Audrey Whobrey, 161 S. Venoy Cir., Garden City, Mich.
KHH2547 Harry Smith, 3448 Linden, Cincinnati 26, Ohio
KHH3125 Howard Stanbarger, 350 2nd Dr., New Philadelphia, Ohio
KHH4010 Bert Quick, 420 Iroquois, Battle Creek, Mich.
KHH4114 Bob Achterhoff, 1491 Lexington, Muskegon, Mich.
KHH0941 Ron Knight, 304 Cottage, West Union, W. Va.
KHI2226 Robert Williams, 745 Wellington, Battle Creek, Mich.
KIC2881 Mike Ripski, 72 Mooney, Plymouth, Pa.
KIC6475 Warren Bartlett, 6 E. State, Johnstown, N. Y.
KHI1830 Mike Knight, Rt. 2, West Union, W. Va.
KHI1953 Howard Quick, 573 Capital, Battle Creek, Mich.
KIC4127 Edward Gruber, 168 Arthur, Horseheads, N. Y.
KIC4696 Jim Hall, 995 Ave. N, Rochester 21, N. Y.
KIC4846 Charles Russell, Wellsboro, R.F.D. 3, Pa.
KIC5382 Robert Fuller, R.D. 3, Nowlan Rd., Binghamton, N. Y.
KIC6657 Albert Martin, 54 East, Ft. Edward, N. Y.
KIC6739 Irvin Bitner, 363 S. Carlisle, Greencastle, Pa.
KIC6830 Dale Reeder, 306 Arch, Williamsport, Pa.
KIC5981 Todd Welly, R. D. 4, Greensburg, Pa.
KIC7755 Harlan Fredrick, 7 W. Green, Johnstown, N. Y.
KID0489 Bill Longo, Box 176, Greensboro, Pa.
KID0637 Howard Edgar, Punsuxatway, Pa.
KID1177 Ed Easton, 245 Erie, Lancaster, N. Y.
KID1206 Leo Dolitz, 14 Roosevelt, Rochester 20, N. Y.
KID1445 Walt Rauhecker, 6500 Martha, Pittsburgh 6, Pa.
KID2079 Paul Woodard, Box 44, Blossburg, Pa.
KIE0023 Harry March, 2958 2nd, Apt. 21, Washington 20, D.C.
XM11132 Don Stroup, 2123 Venables, Vancouver 6 B.C., Canada
XM11133 Dave Forman, 5184 Joyce, Vancouver 16 B.C., Canada
XM11947 Ron Bartsch, Box 329, Abbotsford, B.C., Canada
XM51079 Jack McConnell, 825 14th, Lachine, Que., Canada
XM52042 N. Jack Trehub, 748 Davaar, Montreal, Que., Canada
XM52501 Maxine Trehub, 748 Davaar, Montreal, Que., Canada
Herb Bullock, 243 Beverly Circle, Jackson, Miss.
Herb Klein, 1305 Dickenson, Teaneck, N. J.

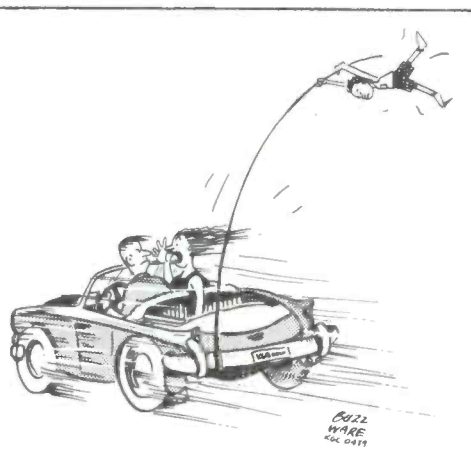

"Geez, where's Junior?"

PART 15 KORNER

by DEAN DETTON, NORTHERN 17

Of all the mail received here about Part 15, perhaps the most frequently requested data is simply general information on what Part 15 is and what you can do with Part 15 gear. I would like to point out that there have been a number of feature articles on Part 15 in S9 and if you would like a short run down on them, here it is:

December, '62—Directory of 159 Part 15 transceivers. 18 questions and answers on Part 15. All about Part 15 identifiers.

February, '63—Constructing a Part 15 transceiver.

March, '63—Further Facts on Part 15.

April, '63—Construct a 1 tube Part 15 transceiver. Part 15 Operating Guide.

May, '63—Construct a 2 tube Part 15 transmitter. Part 15 receiver booster.

In addition, S9's exclusive Part 15 Callbook, which lists all of the stations who have received Part 15 identifiers, has been running each month since the February, '63, issue. A limited number of all back issues are still available at 50¢ each from Harold Weisner, KBG4528/NORTHERN 16, at the S9 offices. This information is for KCC3648, KAH6444, 2Q4717, 10Q0987, 1Q6002, KHA9481, KBA7732, ATLANTIC 410, 8Q1422, KBA-7109/KN1U1W, 5Q1313, and more than 150 others who asked.

We received two nice Part 15 QSL cards this past month which we are running with this column. Both are from the CENTRAL area, one from Illinois and the other from Ohio. They're quite neat looking.

During a contact with Barry, NORTHERN 1677 (also 2Q6114/WA2WAO) we learned

APPLICATION FOR FREE PART 15 STATION IDENTIFIER CERTIFICATE

To register your Part 15 "unlicensed" CB station with S9 and receive your special station identifier certificate, do the following:

- Fill in the application below, or facsimile if you don't want to cut your copy of S9.
- Enclose your completed application form together with a self-addressed stamped (5¢) envelope, in another envelope addressed as follows:

Part 15 Department
S9 Magazine
300 West 43rd Street
New York 36, N. Y.

- Please do not request special identifying words for your station as all identifiers are issued in alphabetical rotation for ease of recording on our records.

APPLICATION FOR PART 15 IDENTIFIER

Name: _____ CB Call: _____

Address: _____

City: _____ Zone: _____ State: _____

Part 15 Channel: _____ Type of unit: _____

No. of units: _____ Date: _____

Signature: _____

BIG CB SAVINGS!!!

- PROTECT YOUR CB MOBILE EQUIPMENT!!!** Auto Burglar Alarm protects your car 24 hrs. a day. Hooks up in minutes, works on all 6 and 12 volt cars. **ONLY \$ 3.49**
- COMMAND SUPER III-3-Element Heavy Duty Beam mounts** vertically or horizontally. (Reg. \$30). **SALE PRICE \$11.99**
- GROUND PLANE SALE!!!** (GP-1) ea. (Disc. Model) Solid Alum. Radials. All Sales Final (6 or more-\$5.00 ea.) **\$ 5.99**

GET ALL OF THAT SIGNAL OUT WITH LOW LOSS FOAM COAX CABLE

- RG58U 50 ft.-\$2.49..... 100 ft.-\$3.99
- RG8U 50 ft.-\$4.95..... 100 ft.-\$8.99

- W-10 5 ft. Center Loaded CB Antennas** fit standard mounts (Reg. \$7.00) **SALE \$ 3.49**
- W90-54 5 ft. Center Loaded Whip** plus top Cowl mount and 54 in. cable (Reg. \$9.00) **SALE \$ 4.49**

Check items wanted. Return ad or order with check or money order. Include postage, excess refunded. 50¢ service charge on orders under \$5.00. Beams and Contact II shipped Railway Express.

CB DEALERS: Write for Quantity Prices!

GROVE ELECTRONIC SUPPLY COMPANY
4115 W. Belmont Avenue
Chicago 41, Illinois Ph. 283-6160

Rush items checked

SEND FREE CATALOG OF GIANT CB VALUES

Name (please print)

Address

City Zone..... State.....

A NEW NAME... for a "grand old company"

MULTI-PRODUCTS COMPANY

OAK PARK, MICHIGAN

Manufacturers of

QUALITY ELECTRONICS

Since 1947

present the same fine products:

- designed for flexibility
- engineered for performance
- manufactured with precision

under the new revised name

MULTI-ELMAC COMPANY

Look for the
Multi-Elmac Emblem
Your Assurance of Quality



MULTI-ELMAC COMPANY

21470 COOLIDGE HIGHWAY
OAK PARK 37, MICHIGAN



that he's in the Part 15 QSL printing business. Barry will be sending out literature and if you're interested in seeing what he has to offer, drop him a card or letter. The 10-20 is Barry Rimer, 212-03 53rd Avenue, Bayside 64, L. I., New York. Or, and this is even more interesting, look for him on Channel 22.

Speaking of NORTHERN, we're pleased to announce that Miss Lilia Neira, NORTHERN 1812, has joined the staff of S9 and will



be devoting much of her time to processing the Part 15 applications and keeping the records. If you have any modifications to your present Part 15 registration with S9, just notify '1812.

See you on the band! Ta-ta!



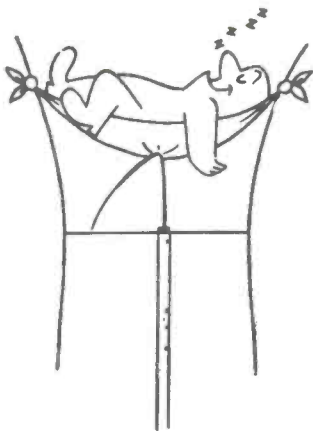

ANTENNAS

by ED NOLL, KCC2618
BOX 23
CHALFONT, PA.

Antenna tuning, measurements and results are confounded by so many variables that the average CB'er and, for that matter, many communication technicians become so frustrated they rely on chance rather than reason in their encounters with antenna systems. Haphazard methods of tuning and testing become the rule. Often antenna-system test instruments, if used, are not used properly and their readings misguide instead of help the technician. Many communications shops are poorly equipped, lacking field strength meter, SWR bridge, and in-line wattmeter. Sometimes instruments are used to tune up transceivers on the bench and, it is erroneously assumed, that it is not necessary to do any antenna tuning or retuning of transceiver for optimum performance after it has been installed in the vehicle. Such procedure relies strictly on *chance*.

Knowing more about antenna systems and how to use antenna test instruments are a definite help in optimizing antenna system performance. However, such knowledge will not give you an immediate answer to all your problems. Too many factors are involved. But you will learn to anticipate inconsistencies and develop an understanding of how variables can be held under some reasonable control.

TUNE AND RETUNE

Every set that comes in for repair should be set up on the bench, checked, and, when necessary, retuned. A 50-ohm dummy load should be used for this purpose. By so doing you have set up the equipment for operation as it was designed; namely, to deliver an optimum signal into a 50-ohm resistive load. The work of the communications technician does not end with this adjustment. It ends only if the unit is to be connected to an antenna system that displays an exact 50-ohm resistive load. This assumes that the antenna system has an exact 50-ohm resistance and no reactive component. One may come near to this ideal situation for a base sta-

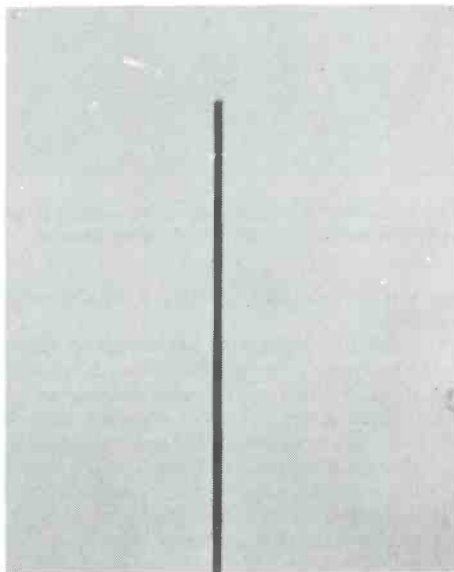

Peaking a Helical-Wire Antenna by Trimming Wire End.

tion installation; the possibility for an idealized situation in a mobile installation is slim. You may come nearer to idealized performance if the antenna is tunable; but this means that the antenna has to be tuned and the communications technician's work has not ended at the bench.

Setting up the unit for performance into a 50-ohm resistive load first brings the unit close to optimum tuning. It is the initial important step.

Using the service shop antenna as a standard in place of a 50-ohm load is not the best procedure unless the very same type antenna, in a roughly similar installation plan, is used for the transceiver under adjustment. The procedure is acceptable if you can be certain that

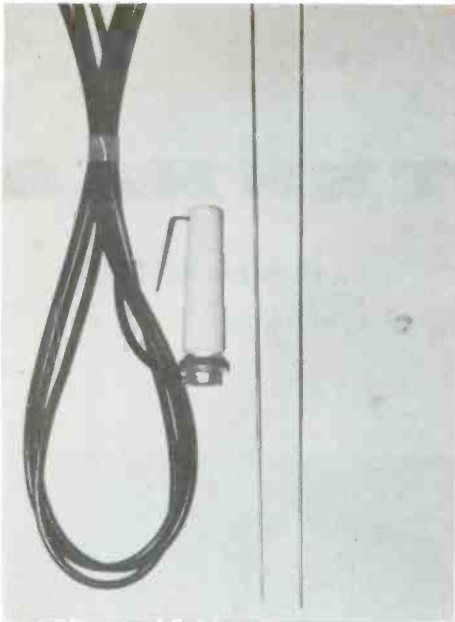

Crater Lake Short Antenna Showing Permanent Fixed-Length Element and Telescoping Tune-Up Element.

your test antenna does display a 50-ohm resistive load.

There is one important advantage to tuning up the transceiver to match a 50-ohm resistive load. It is possible to connect the transceiver to a suitable antenna system knowing that the unit itself has been set up for optimum feeding of a 50-ohm termination. Thus it is possible to tune the antenna for optimum results without changing the transceiver adjustments. This permits you to bring the antenna system as close as possible to the idealized impedance. Some antennas are or can be brought near to this value and, at this point, you have established optimum operating conditions. In fact, if you have gotten maximum output and minimum SWR for exactly the same settings of the transmitter tune and load controls, the antenna is displaying the same impedance characteristics as your dummy load.

If the above situation is not met you at least know you have brought the antenna system performance as near as possible to the 50-ohm resistive value. You can now retouch the transmitter tuning and loading for maximum output and minimum SWR. If the match is reasonably close, the same transmitter adjustments will produce maximum output and minimum SWR.

However, if there is quite a departure between antenna system characteristics and output impedance of the transmitter, maximum power output and minimum SWR may not

occur with similar settings. In this case, the settings that produce the highest reading on a field strength meter should be used.



In-Line Wattmeter Can Be Used To Check SWR, Outgoing Watts, and Reflected Watts.

TAMING THE VARIABLES

The following procedures and the necessary test instruments to back it up should be employed by anyone who does a considerable amount of CB radio installation and service:

1. Adjust the transmitter for optimum performance into a 50-ohm resistive load in the form of an actual dummy load or an antenna system that displays this idealized load. The former method is preferred from the standpoint of reducing interference and complying with FCC regulations.

2. If the antenna system with which the unit is to be associated is tunable, you can now tune the antenna for optimum performance without readjusting the transmitter controls. After the antenna has been optimized you may wish to retouch transmitter controls ever so slightly for optimum output.

3. If the antenna can not be tuned to the idealized impedance some retuning of the transmitter of a reasonable amount may be necessary to obtain optimum results as indicated by maximum output and minimum SWR.

4. If there is a substantial diversion between antenna characteristics and output characteristics of the transmitter, the transmitter may have to be significantly retuned. In this case minimum SWR and maximum output may not occur at the same transmitter settings. In this case it is better to rely on field strength readings.

From the above you can visualize the inconsistencies and torment with which you can become involved if there is no logic to the tune-up approach. Suppose you tune up a transmitter on a base station antenna which in itself displays a considerable reactance and other than

a 50-ohm load. You now take the transmitter and install it in a vehicle using an antenna of characteristics that are not the same as the base station antenna and also other than a 50-ohm resistive value. You have now multiplied the variables (confusion squared). If you now tune the system with no or inadequate test equipment more confusion results. Although the instruments may be good you are likely to have erroneous readings. You may decide to test out the system by contacting another mobile unit moving along a twisting and hilly road, under and over bridges, toward and away from high-tension lines, etc. The variables are multiplied again (confusion cubed).

GROUND?

Only some antennas display the same characteristics regardless of their mounting position. Mostly this favorable condition is only displayed by certain types of base station antenna. As a rule the antenna characteristics depend quite a bit on the ground system that associated with the antenna. In the case of a base station antenna, system characteristics may be affected by surrounding obstacles, antenna height, the place at which the ground is attached to the antenna system, and the actual type of ground. In the case of a vehicular installation the ground characteristics depend on the placement of the antenna, the vehicular electrical system, the car bonding, etc.



Using Included Wrench To Tune Up CB Section of Antenna Specialists CB-AM Antenna.

What these conditions tell us is that the antenna should preferably be tuned after the antenna has been placed in its exact mounting position. If there is any significant mismatch problem the overall length and type of transmission line also influences the actual impedance presented by antenna system to the transceiver. Thus the installation should be brought as near as possible to the final installation before antenna tuning is undertaken.

For these reasons too it is not wise to assume that a transmitter tuned-up at the bench will give optimum performance if it is installed in a vehicle without tuning.

TUNING THE HELICAL WIRE

Many of the helical wire antennas are constructed for a reasonably good SWR ratio over all of the CB channels when connected to a transmitter with a 50-ohm resistive output impedance. If any, there are too many turns rather than too few for the average installation. Thus if you can mount the antenna in its final position with everything set up as it will be in normal operation, it is possible to clip the end of the wire until peak output and minimum standing wave ratio are obtained.

However it is important again that this be done after the transmitter has been tuned up for optimum performance into a 50-ohm resistive load. If this is not done you may find you have cut-off too much of the helical wire when you retune the transmitter or attach a transmitter that has been tuned for loading into 50-ohms.

If there is a mismatch problem the antenna tuning can also be influenced by the length of the transmission line. Thus the actual line that will be used should be installed before the antenna is trimmed.

In doing the actual trimming, the SWR meter should be connected in the transmission line at the transceiver. It is helpful to use an in-line wattmeter because you can keep a check on both power output and SWR ratio while you do the trimming.

The results of your trimming, and whether or not the antenna should be trimmed, can be ascertained by SWR measurements at the center and both ends of the CB band. For example, channels 1, 10 and 20 could be used. The very end channels need not be used nor the exact center channel.

If the antenna could stand some trimming it is indicated by a rising SWR ratio as the measurements are taken on channels 1, 10, and 20. In a typical example the SWR ratio might be 1.25 to 1 on channel 1 and up to 1.65 to 1 on channel 20. Trimming could bring ratios down to readings between 1.05 to 1 and 1.2 to 1.

Continued on page 51

CB ANSWERMEN

by LEN BUCKWALTER, KBA4480

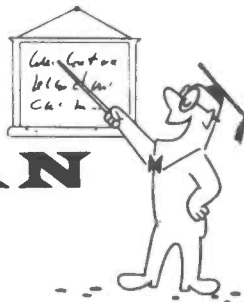

Editor's Note: Readers are invited to ask the CB ANSWERMAN any questions which they have regarding the CB service. Address your questions to Len Buckwalter, KBA4480, Wilridge Road, Georgetown, Conn.

PLANE TVI

Since I put up a ground plane, my neighbor complains that she doesn't get the TV channels she got before. This happens even when I'm not transmitting. Is it possible that ground plane, just being there, can interfere with her TV reception?

C.W., Middletown, N. Y.

It surely can. Energy from the TV station may enter your ground plane, circulate among the elements, build up in strength and re-radiate—as if your antenna were a miniature TV transmitter. The real problem, however, results from the spacing between TV and CB antennas. It's possible that TV energy off your ground plane reached her antenna out of step with the direct signal pickup from the station. As signals mix they cancel each other and cause much-weakened TV reception. This, incidentally, is the basis of the beam antenna; various elements are used to reflect and direct the energy—but spacing is chosen so reinforcement, rather than cancellation occurs.

The remedy is to vary the distance between antennas. Since TV waves are quite short in length, try moving either antenna a few feet at a time to destroy the unfavorable spacing that exists. If your antenna installation uses guy wires, they might be acting as TV channel resonators. These can be broken up by egg-type insulators or re-

placed with some non-conducting material like fiber glass line.

MOBILE POWER

I have a unit that works OK as a base station. But when using it as a mobile rig, the power will increase or decrease with the speed of the car engine. I would like to know a way to cure this without much cost.

L.R.J., Stockton, Calif.

Assuming that your CB equipment and car electrical system are in good condition, there is no inexpensive cure. The problem is in the operation of the car's charging system. With a 12-volt storage battery, voltage to the rig will shift between approximately 12.6 volts and 14.8 volts. The higher value occurs as the voltage regulator permits the generator to charge the battery. The shift is comparable in a 6-volt system.

Actually, the effect on the CB rig may not be as bad as you suspect. If the power change is judged by viewing the brightness of the rig's pilot lamp, the method tends to give an exaggerated indication. During the power shift, which amounts to about 15%, the RF carrier changes by a negligible amount. An interesting parallel occurs in the case of house current; with a mere two or three percent drop in power, you'll see a noticeable flicker in the light bulbs.

The easiest technique to keep output power highest costs virtually nothing. If the car is standing still while you're transmit-

ting, just depress the gas pedal so the engine turns over at a fast idle.

PRINTED CIRCUIT REPAIR

I have a handie-talkie with a printed circuit. Due to an accident, several of the printed wires broke. How can these be repaired?

L.C., Helena, Montana

Breaks in the copper foil pattern are readily repaired by making a "bridge" of hookup wire. As shown in the drawing, solder a short length of hookup wire across the break, using as little heat as possible to prevent the foil from separating off the board.

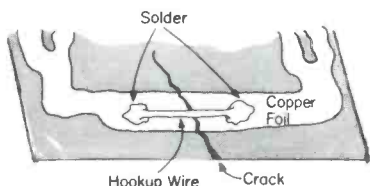

Sometimes it's difficult to see where all

the breaks have occurred. These may be discovered by viewing the board with a strong light behind it. Cracks will show up as thin hairlines that are not visible under usual room light.

DF'ing

I plan to build the "CB DF'er" described in the October, '62 issue of S9. Since it is to be used for finding boats in distress, how can I get maximum range out of it?

B.T.L., Boston, Mass.

One simple technique for detecting extremely weak signals in a radio-direction finding system is to add a BFO to the CB receiver. Even when modulation on the signal is inaudible, or the S-meter shows only noise, the BFO can often reveal the presence of a weak carrier. It is heard as a tone in the loudspeaker.

In operation, the BFO is turned on and the directional loop antenna rotated until the tone is no longer audible. This indicates the null point and thus the direction of the station, as detailed in the DF article. **S9**

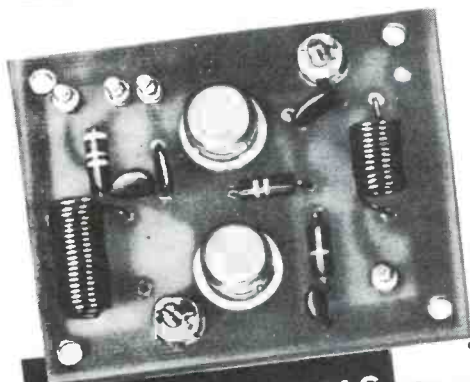

TWO "CB" SPECIALS FROM WRL

Receiver is specially designed, superhetrodyne circuit. 9-volt battery included. Push to talk switch.

Write for complete information
Dealer inquires invited

WRL

SPACEMATE TRANSCEIVER

The finest two-way radio on the market at this price

FEATURES

- 2-way receiver and transmitter
- No license or test required
- 9 transistors plus one diode
- 1 or more miles range
- 46" telescope antenna
- Choice of channels 11 or 16

In Pairs, Each \$29.95

Single, Each \$34.95

INCLUDED FREE → leather case and strap, battery and earphone

WORLD RADIO LABORATORIES

3415 West Broadway Council Bluffs, Iowa
F.O.B. WRL



2-STAGE "CB" NUVISTOR PREAMPLIFIER

GUARANTEED TO IMPROVE RECEPTION ON YOUR CB RECEIVER OR TRANSCEIVER

- Finest Printed Circuit Board
- Wired, Complete with 2 RCA 6CW4 Nuvistors
- Can Double Sensitivity Over 20 db Gain
- Use with Superhet or Regen Units

• Actual Size — 2 3/4 x 2 3/16

\$11.95

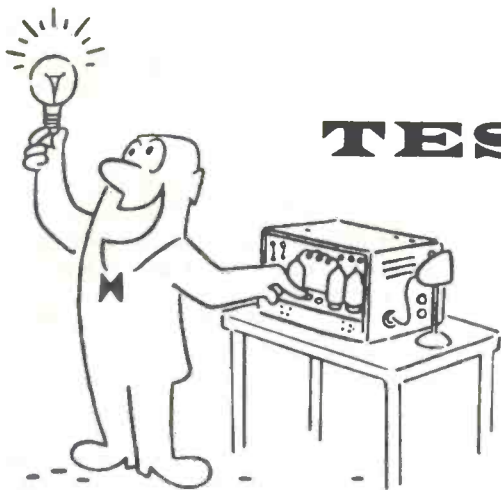

TEST GEAR

by **HERB FRIEDMAN, 2W6045**
2271 KNAPP STREET
BROOKLYN 29, N. Y.

We've received many letters asking us to recommend test equipment for a "basement" shop. While we will usually answer questions about a specific type of instrument, you can imagine the difficulty in recommending a shop-full. Since a CB'er can also be interested in other areas of electronics, such as Amateur, Tv, hi-fi, general experimentation, etc., what may be an ideally equipped shop for some would be a waste of money for others. Only *you* know where your interests lie so only *you* can make a selection of test gear.

Many books have been published whose purpose is to help the reader understand what test gear he *really* needs, how to get the most out of it, and how to decide what instruments to buy. After a fast survey of test equipment books we have come up with four which have particular value for the CB'er. They are written in down-to-earth style, avoiding the pseudo-scientific gobbledygook which fogs up most technical explanations.

Heading our must-read list is "It's Easy To Use Electronic Test Equipment" by Klein (2Q6862) and Gilmore, published by John F. Rider. It is one of the easiest-to-read, understandable books on test equipment I've come across. Written with a light touch, the book starts with the basic VOM and then progresses in a logical sequence to the theory and practice of the VTVM, oscilloscope, RF and audio generator, bridges, and a batch of

other test and measurement instruments. (The actual circuits of the instruments are shown and if you want to lift a circuit you'll find the parts values are given.)

Not only are the features of each instrument analyzed in terms of *what it means to you on your test bench*, but you look over the authors' shoulders while they use the instruments in step-by-step troubleshooting and alignment of a variety of RF and amplifying equipment.

The inside technical stories of the instruments are spelled out in detail. Not only are there circuit comparisons of brand name instruments, but the circuits are analyzed in practical terms of what they will do for you in terms of troubleshooting your CB, ham, hi-fi, constructions projects, etc. In fact, by consulting "It's easy To Use Electronic Test Equipment" before you equip that "dream shop" you'll probably save yourself a pocket-full of cash (you'll avoid the problem of purchasing the wrong test equipment).

The three other books we recommend will help you realize the maximum out of the instruments you buy; they are in the "hint-and-kink" category—giving those odd uses which are not usually given in the manuals which come with the instruments. These are the time saving ideas which usually take years to learn.

Continued on page 52

CB CHIT-CHAT

**INDIVIDUALS AND CLUB MEMBERS!
SEND US ITEMS FOR THIS COLUMN!**

TO JOHN KREJC, 2W4586

40 LANZA AVE.
GARFIELD, N. J.



WANT TO MAKE MONEY? S9 has a nationwide staff of AREA PUBLIC RELATIONS EDITORS who act as our representatives in the field. We are always looking to expand this force with good workers. Our A.P.R.E.'s can earn some nice money too, and many are already supplementing their regular incomes substantially by representing us. We're especially interested in persons to act in this capacity in the following call areas: 2, 6, 9, 14, 16, 17, 18, 19, 22, and 23, although ambitious S9'ers in all other areas will also be most welcome. Drop us a note and tell us about yourself.

COMING EVENT—The First Anniversary Celebration of the Fairfax-Prince William CB Radio Club will be held at the American Legion Hall, Fairfax, Va., Sunday, July 21, 1963 from noon till 7.

Recently formed, The Midwestern CB Radio Club, Inc. The club is about 5 months old and with a membership of over 50. President of the newly formed group is William Weichlein, KHB0693. Good luck.

Members of the W.N.Y. Citi-Banders Club, Inc., of Lockport, N. Y. recently celebrated their second anniversary with a gala party held at the local V.F.W. Hall. The dinner was followed by the installation of recently elected officers and a program to honor the retiring officers. The club meets on the last Sunday of each month and monitors channel 12.

The Sullivan Trail Citizens Band Club will show a film to members entitled, Lease on Life, which pertains to CD. President of the group is Genn Cooper, 20Q1022, Vice President, Don Mann, 20Q2229. Let's see who brings in the most KID calls as members?

Richmond, Virginia, branch of REACT in recent search and rescue operations on the James River for two students lost in a canoe accident was told on Virginia's only 50,00 watt radio station, WRVA. H. Gordon Winn, 5Q2524, emergency coordinator for Emergency 13 Association Inc., was interviewed by Ed Whitehead, KCI6040, News Editor of WRVA Radio, in Whitehead's program, "Sideviews on the News."

COMING EVENT—Alliance CB Club, Ohio is having their picnic, June 30th, Beechwood Park, one half mile west of Alliance. Local members will standby on channel 9, for directions. Call Traffic Control.

President of the Tri-County Citizens Radio League, Akron, Ohio is Charles Patterson, 19W6399. The club is looking for a new editor of their club paper—anyone interested?

Editor of the Carnation City CB Club, Inc., club paper is Dave Morrison, KHG5047. His boss and president is George Bowman, KHG2610.

Again, The Jackson CB Radio Club, has been used Sheriff's dept., by the use of their radios. They patrolled for the purpose of emergency to help the police and the area where a supermarket was robbed, and relayed

back to the officers in charge, which lasted for quite a while. Several times the club has been used for searches and other emergencies.

The Hamilton County CB'ers, in the heart of the Adirondack Mts., together with the Conservation Dept., State Police and Speculator Fire Dept. (Which operates CB) were called to join in a search at 9:30 p.m. recently for a Boy Scout, who had become separated from his patrol while on a weekend camping trip. The boy was found near the top of the mountain, safe and sound. President of the group is LeRoy P. Weaver, Lake Pleasant, New York.

Members of the Waukesha County CB Club of Southern Wisconsin attended a Fox Hunt recently, sponsored by the Hook and Shell Club, Mapleton, Wisconsin. An emergency unit has been formed which has been incorporated into the club as an auxiliary unit to be used to help CD and civics. Thanks, Sally, KHA0677.

35 CB'ers made a surprise visit to the REACT club of Orange County recently. Coffee and donuts were on the house. The communities of Whittier, Commerce, La Puente, Pico Rivera, (RMF) La Mirada and Norwalk were represented. Jim Stratton, KEJ0294, was leader of the caravan and Gene Grant, KEJ6251, with May Grant, KEJ1399 were tail waggars.

Channel 13 was cleared of all traffic, recently by the Marine Watch of Hermosa Beach, California in order for them to aid in the search for a marine vessel in distress. The Coast Guard handled the search with the FCC monitoring the channel to aid in pinpointing the vessels location. The distress call came in on the CB Band and the Marine Watch finally found the location as off Anacapa Island. The group worked for several hours, relaying messages and instructions to the stricken boat.

"HELP NEEDED" is the plea from Bob Durnin, President and Editor of the Tri-County Emergency Communications Net, Inc., N.H. club paper the Tri-County Bulletin. Help is what they need to continue this fine bulletin. So lets all pitch in.

Recently formed the CPR CB Radio club of Round Top, N. Y. with Paul Vosburgh, KBII1904, president. The membership is at 20 and growing. The club reported a fallen tree, and in turn called the local F.D. and electric company. Sec'y and Treas. is Pat South.

COMING EVENT—Maumee Valley, 1963, CB Round-Up, Fort Wayne, Ind., Sept. 22, Hessen Cassel Recreation Hall, Jack Dold, KHA9478, General Chairman.

Another new club the Central Oregon CB'ers. The

club covers, Bend, Redmond, Madas, and Prineville in Oregon. Recently the club was asked by the local Sheriff of Prineville, to form a Search and Rescue unit, of which they are working on. Prex John Schulke. What no call?

The Lake City CB club of Marion, N. C. with a membership of 48 and as many CB units, held a practice run after their monthly meeting, assisting eleven doctors and the hospital in the event of a telephone and communications failure in the area. Club president, Walter Williams headed the test run. Walt, and Dean Wall, with Chief George Brown, McDowell County Rescue Unit was stationed at the hospital. The club and Rescue Unit work closely in any and all emergencies that arise in the McDowell County area. The mission was successful and another test will be made soon. Channel 18 was used, 11 is monitored in the Marion area.

The Citizens Band Assn. of South Ala., Inc. meets in the Florida Room of the Florida Bowling Lanes, Mobile, the second Friday of each month at 7:30 p.m. Organized in 1961 by 7 charter members, this active club now boasts a membership of 139. President is J. C. McNair, 8Q1095. Capt. Walter Nelson, 8W2611, official club monitor, stands by on channel 2, about 18 hours daily. Club info should be directed to—8W1413 D. C. Lagrave, 166 Glenwood St., Mobile, Ala. CBASA, assisted by the womens club, CB Partyline Club, has been active in 2 polio immunization programs supplying county-wide communications for 81 post and runners for vaccine delivery. (98% of Mobile County's population received the vaccine).

CBS EYE'S (The Citizens Band Social Eyes) President of the newly formed club is Bob Koss, KHB2815. Meetings are held the 1st Saturday of each month. The club is from Indianapolis, Indiana.

Report from Crystal Cracker Club, Lee County, Pennington Gap, Virginia. Membership 30 strong, the club is led by Elbert Lamar, 5W1843. The club was commended for their emergency operation in CB communications in the Flood Disaster, April, 1963. These people are now among the members of RACES and other CD communications, and carry the personal I.D., with their mobiles having a CB CD decal. Hats off to Elbert, 5W1843.

BIG BLAST—The Night Hawk Net sponsored their 2nd Annual CB Blast, Sat., May 18th, Johnson Park, Grandville, Mich. The program was open to all CB'ers and their friends. Two CB units were given away. The Grand Valley 11 Meter Club sponsored a gigantic oxtroat supper from 4 p.m. till 7 p.m.

COMING EVENT—The CENTRAL OHIO CB ASSOCIATION will hold their CB Jamboree, July 13th and 14th. Jamboree Chairman is George W. Martin, 3629 Ontario St., Columbus 24, Ohio.

COMING EVENT—The Southern Tier CB Radio club will hold its First Jamboree, Saturday, August 3rd, Ross Park. General Chairman is Robert T. Reagan, 86 South Washington St., Binghamton, N. Y. The functions of the club include CD, election returns, and mobile emergency radio work.

RMF, joined with the "Fireball Caravaners," a camper and trailer club, which has a great number of their members in various CB clubs, in a trip to the Hi-Desert. He met several members of the Hi-Desert CB Radio Club. The club is now a REACT Unit. President and Chairman is Wayne Hanselman, KFA0471. How that Forster gets around. Hey, Bob, when are you do in Jersey? How about that Francis Williams, whose ??? foot antenna, in the mountains, high above the desert, enables him to cover the entire area and keep in touch with every situation. 11W9374 has had many lively and interested experiences. Don't worry about a thing when 11W9374 is on the air.

A little story from Marge De Vault, KEJ1980, Desert CB Club. About two years ago when Marge first went on the air, she heard the Desert private patrol—T. Moses, 11W1721 trying to reach his base, not able to make contact, eager-beaver Marge offered to relay. She was able to reach them and they informed her to advise the mobile unit they would turn the beam around and try to reach the unit. So Marge, trying to help, didn't quite understand this and she advised the mobile unit as follows—Tom you had better hurry home, for Betty says if you stay, she will burn the beans. Oh, well. RMF, you did it again.

From Ione Petersen comes the news of a new organization of CB'ers (unnamed) in the Greenville, Michigan area. The club is headed by Don Shroll, KHG8348. Their recent meeting was attended by 23 CB'ers.

Another new club who hails from Saginaw, Michigan, called the Saginaw Valley Hobby Radio Club. Let's hear more.

COMING EVENT—What promises to be the largest CB Jamboree ever staged in Southern California, will take place in the "ALL AMERICA CITY," Lynwood, Calif. Dates for this event will be July 26-27 and 28th at the Lynwood Community Center. Contact 11Q4800 unit 12 on channel 9. Lynwood is between Los Angeles and Long Beach, just off the Long Beach Freeway.

Good luck to Al Zukosky, 2Q0574, in his second term in office of the CBRRL, Hudson Essex Chapter. Keep the faith Al.

Recently formed, The Birmingham REACT, sponsored by Nelco Service Co. and Electronics Assn., monitors channel 11—24 hours a day and switches to channel 19 for emergency work.

COMING EVENT—Coosa Valley CB Jamboree, August 10-11th at Lake Rhea, Attalla, Alabama. President of the group is Olen Hibbs, 6Q6533. Any information contact 165 Argyle Lane, Gadsden, Ala.

Citizens Band Radio Club of Walker County is lead by president Fred A. Shivers, KDB4564.

Blount County CB Radio Club, Ala., meets the first Friday of each month. The club has helped form the Blount County Rescue Team. The Unit meets every Friday to study rescue techniques and First Aid.

Any club wishing to exchange club papers, The SQUELCH, club paper of the Broward Citizens Radio Club, Inc., P.O. Box 8092, Fort Lauderdale, Florida, welcomes all and any. The club would like to exchange ideas, area wide, would be of mutual benefit.

While a great many CB Clubs across the nation have fallen by the wayside during the past two years, the DELAWARE VALLEY CB CLUB goes marching on. The club was founded upon strong principles and worthy ideals, determination to never lose sight of their goals and the continual effort to serve their membership, has held them on a safe and steady course. GOOD LUCK.

GOOD LUCK to the CLUB, THE DELAWARE VALLEY "CB" ASSOCIATION, First in the First State, P.O. Box 1986, Wilmington 99, Delaware.

COMING EVENT—One of the latest and most important projects the South Western Ohio Citizens Band Radio Association is planning, is their FIRST NATIONWIDE CITIZENS BAND RADIO JAMBOREE. The event will be held at the Lebanon Fairgrounds, Lebanon, Ohio, Sunday, August 25, 1963. The club holds their monthly meetings the 2nd Sunday of each month, at the Municipal Building, Mason, Ohio at 2:00 p.m. The club boasts a membership of over 70.

The Central Alabama CB Club has a membership of 20 and is affiliated with National REACT, Civil Defense, and the Sheriffs Dept. The club meets the 1st and 3rd Tuesday of each month at Martins Restaurant, Jemison, Ala. President is Kendall F. Martin, KDB7524. That's why the meetings are held at Martins.

President of the Citizens Radio Club of Montgomery, Ala., Alvin Gregory, KDB1021.

Judy Mix, 18Q9199, received a microphone amplifier from THE FAMILY CB CLUB, Nianle, Ill. Judy is in an iron lung and the amplifiers a real help to her. Proceeds from a chili supper, which was sponsored by the club will pay for the gift.

W.N.Y. Frontiersmen CB Assn., made and sent 100 Easter baskets to the Childrens Hospital of Buffalo and the Childrens Home of Lockport, N. Y. The baskets were distributed to the children on Easter morning by Peter Russell, KIC1734, president. The club wishes to exchange club papers with any clubs. Write W.N.Y. CB Journal % Wm. Harms, 928 E. Delavan Ave., Buffalo 15, N. Y.

Western New York Emergency Net will be monitoring channel 9 this summer if any mobile unit passing through Buffalo needs assistance. The channel will be monitored from 8 a.m. to 11 p.m. New prexy of the club is BOB HUGHES, KIC2794.

Officers of the Fayette Westmoreland County Citizen Band Assn., President, John Koenig, Vice President, Pat Tatano, Sec'y, Sally Lock.

"CLEAR 9," club paper of the 5 Watter CB Club Inc., Lansing, Michigan looks good. Lots of Luck. President, Don Waite, 19Q8659, says he found a better way for getting good gas mileage—a pushmobile.

Another successful "Raid" drill was held recently. "Raid" of course is CRL's emergency communications group, RADIO ASSISTANCE IN DISTRESS. The coordinators of this event were Barney Chaiken, 18QA-0200 and Gordon Wood, 18QA1840.

The article Unfortunate Accident, in the recent CB Chatter, tells via a visiting CB'er from the Canaveral area that Paul Ford, KDH1195, Merritt Island, was accidentally electrocuted while working on his CB antenna. The Metropolitan Club of Miami wishes to express their regret and sympathy to the family and this should remind all to be careful. See June S9.

President of the Silver State Citizens Band Assn. and Washoe County Boat Squadron, George O'Dell, 12W1191, Vice President, Stan Russell, 12W3993, Sec-Treasurer, Nancy O'Dell, KFC1210, Editor of their paper, Silver State Scribbler, is good 'ol John W. Riggs, 12Q3211.

REACT of Orange County held a "Swap Meet" recently in Costa Mesa, Calif. During the day a drawing was held and a HC20C Transceiver was given away.

The "WHITTIER RAMBLERS" a trailer club from the Whittier Calif. area, which is strictly a trailer outing group, and not a CB club, spent an enjoyable time in Riverside County recently. The club does have a number of CB'ers in their group.

REACT of South Western Los Angeles County, held their first official "Coffee Break" since being organized, at Uncle Toms Pancake House, Pacific Coast Highway in Long Beach. The affair proved to be a real blast. About 50 members and their families turned out, plus about 60 visitors from the Whittier, Pico Rivera, (RMF) and Bell Gardens area.

The CB Monitors, a San Gabriel Valley Club sponsored an informal coffee break in La Puente, April 21st. An enjoyable social evening was spent by approximately 35 members and visitors.

The Little Rhody CB'ers, Providence, R.I. were chartered the 20th of March. At the present time the club boasts a membership of 30. Channel 11 is their main monitoring channel and 15 as an alternate. President of the newly formed club is Joe Caccia, KBA-7213; Vice President, Tony Moretti, KBA7213; Sec'y, Tony Calore, KBC1409 and Treas., Bruce DiMeo, KBA7405.

The Merrimac Valley CB Club of Lawrence, Mass., which was formed in Feb., boast a membership of 60, and hold their meetings the 1st Sunday of each month. The club monitors channel 9. Secretary is Joan Peters, KBA8271.

Recently the 5C's, Cambria County Citizens Communication Club displayed their value to the community and surrounding areas when they responded to a request for aid in locating a lost Boy Scout. The club from Johnstown, Pa., was recently appointed an official REACT Team.

COMING EVENT—Evansville Citizens Radio League, Ind., will hold their 2nd Annual CB Jamboree, August 11, 1963. For more info contact: L. Jo-genson, 814 Seiler Ave., Evansville, Ind.

COMING EVENT—Milwaukee CB Club to be held at Bobs Resort, Tichigan Lake, Waterforc, Wisc.

COMING EVENT—CB Club of Lansirg, Michigan will hold their event at the 110th Armory, June 30th, corner of Marshall and Saginaw, Lansing, Michigan.

COMING EVENT—Wabash Valley Citizens Radio League, 2nd Annual CB Jamboree at Turkey Run State Park, Ind., to be held July 14, 1963. Contact Ron Divine, P.O. Box 911, Terre Haute, Ind.

Good luck to Walt Histed, KDH1835, in his recent and most successful Editorship of the Manasota CB Modulator, club paper of the Manasota CB Club, Sarasota, Florida. Looks terrific, Walt. The paper will add a swap and shop column next month. What happened to the feature article President of the group is Randolph Cookerham, 7W2039.

From the TRANSMITTER, club paper of the CB RANGERS, BULTER, PENNA., comes the news of a few more Jamborees that we had missed.

COMING EVENT—Penova CB Radio club of East Liverpool, Ohio will hold their picnic, June 23rd at the Lisbon Fairgrounds, Lisbon, Ohio.

COMING EVENT—July 7th the Allegheny Kiski 5 Watters of New Kensington, Pa., will hold their picnic at the Sportsmens Club, Freeport, Pa.

COMING EVENT—Western AREA CB club of Bulter, Pa., JULY 13-14th, will hold their Jamboree at the Farm Show Grounds in Bulter, Pa.

COMING EVENT—August 25th the Sociable 5 Watt of Beaver Valley, Pa., holds their picnic at the Bradys Run Park Shelter, #10, Route 51, Beaver Falls, Pa.

Something to see and have is the TRI-STATE AREA CALL BOOK CLUB DIRECTORY, published by the CB RANGERS, BULTER, Pa. You talk about class, well this one has it all over. FINE JOB. Members of the



club should feel proud to boast this to anyone. We'll cover this more in August.

Well here we go again John. The Chatterbox, club paper of the Cereal City Citizens Band Radio Club, P.O. Box 91, Battle Creek, Michigan would like to exchange club papers with all. We have mentioned this many times before, and the club reminds us of it again.

COMING EVENT—The Cereal City Citizens Band Radio Club, Battle Creek, Mich., holds their Jamboree, JULY 21st at the Kellogg Airport, Hanger #4, Battle Creek, Michigan. Monitor channel 9 and 11.

COMING EVENT—8 STATE CB JAMBOREE, JUNE 30, 1963, MANCHESTER, Pa., sponsored by the YORK CITIZENS BAND ASSISTANCE CLUB. See you all there. We will.

COMING EVENT—The South-Eastern Pennsylvania Citizens Radio Club will hold its 2nd Annual Picnic at Chester Park, Area #2 on July 14th with July 21st as a rain-date, from 12:00 noon till ?? Price \$1.50 per person. Door prizes—Entertainment—Plenty of FOOD (YA FOOD, JOHN) Children under 14 years—free. Guess my wife shouldn't have a problem!

COMING EVENT—EASTERN STATES CB JAMBOREE PICNIC, Schupps Grove, August 25th, Rain-date Sept. 8th, 10 a.m. till dark.

A.P.R.E., Jim Cross, KCF0823, attended the monthly meeting of the Hub Citizen Band Club which is held on the second floor of the Hagerstown, Maryland Y.M.C.A. on the last Thursday of the month. The meeting was very orderly and was conducted by President Nelson Garling, 4Q1028 and was attended by a good turnout of members. Local CD officials talked with the group and received a general list of members that could be available in a disaster or local emergency.

President Art Ashenfelter, KCF0549 of the Mountaineer CB Club reports the club helped a Cumberland base to try to get her mobile, who was not heard from in sometime. At this time several days of rain had fell and she was in fear that her father might be in trouble. KCF0459 and KCF2417 drove to the spot and helped him retrieve his trailer from the waters, which were at flood stage. Good work boys, let's hear more from your section.

The Hagerstown Unit of REACT formed by charter members, Russell Rhinehart, KCF1492 (Make the BIG SWITCH, RUSS) and Jim Cross, KCF0823 became an official REACT team on Sept. 13, 1962, with an initial membership roster of 12. Hard work and plenty of talk with CB'ers around Hagerstown area has built up the respect of CB with their motto, "Dedicated to civic duty and emergency responsibility with two-way radios for coordinated use in Washington County.

Then from Virginia, came John S. March, Sec'y of the Fairfax-Prince William CB Club who on April 29, 1963, visited this writer at his home and enjoyed a nutty night with Your Club Editor. We were caught by surprise, but then rolled out the red carpet, with all the holes in it and enjoyed a pleasant evening. Did you ever make Phila., that night? John's wife had more to say to him in the car than at my home. Well John, we'll see you on the 21st. Everybody lock their doors.



The Norwalk Citizens Band Radio Assn. meets the first Wednesday of every month at 7:30 p.m. sharp in the East Norwalk Library, Van Zant St., East Norwalk, Conn.

COMING EVENT—CB Clambake to be held at Santo Grove, Strawberry Hill, Norwalk, Conn., Sept. 1, 1963. Keystone Profile of the Month is Joe Osisek, KCC0446, who was one of the first members of the club and serves on the House and Program Committee. The Profile is a part of the Keystone 11 Meter News, club paper of the Keystone 11 Meter League, P.O. Box 45, Pottstown, Pa.

President of the Logansport CB Club is Keith W. Kehr, KHA5886. The club monitors channel 8, and is thinking of erecting signs at city limits to help traveling CB'ers in information.

COMING EVENT—The Tri-State Communication Association will stage a CB Jamboree, June 28, 29, and 30th, Grays Station, Washington County Fairgrounds, Tenn. Prizes and program for three days. Howard Brown, KDB8142, Route #3, Blountville, Tenn., is Chairman.

COMING EVENT—The 11th National Hillbilly Homecoming, 2nd Annual Hillbilly CB Jamboree, July 11, 12, 13 and 14th, Blount County, Maryville, Tenn. The site is located between the Smoky Mountains National Park and the Great Lakes of the south.

Florida's Gateway City—Jacksonville—has recently reorganized its Citizens Radio Organization, and elected "Tex" Bonham, 7Q1401, president and Dick Hansen, KDH1988, vice president. During the month of March, the club has given financial aid, food, and clothing to two very and deserving families.

On Sunday, April 7th the Jacksonville CB Club sponsored a CB Club picnic and rally, which was held at the Jacksonville Zoo.

Lake Placid 5 Watters Club, N. Y., a newly formed club recently elected Donald Cave, KID0733, president. Presently the club sports 15 members. The club monitors channel 11.

The first Wednesday of each month at 7:30 p.m. is the regular meeting of the CB "5" Watters of Virginia, Newport News, Va. A door prize is presented each month. Channel 15 is their CD emergency freq. and 9 is their REACT freq. President of the club is Frank Foster, 5Q3454.

A meeting of the newly organized radio club, "The CB Knights" was held recently at Osips Tavern, Leonardo, N. J. President of the club is Joseph Narze, 2W2128. Stan Sliwa, 2Q5760, is the publicity officer and editor of the club official publication, "The Channel Splash." Meetings are held the first Thursday of each month. For more info contact: Ed Parsons, Vernon St., Oakhurst, N. J.

The 11/27 Club of Ventura, Calif., reports that the MARINE WATCH, which had its official start on March 16th, is well established. The club states that additional help can always be used, and asks that anyone interested contact Snapper, KEJ3867 in Ventura. Channel 13 is the official MARINE WATCH CHANNEL.

The 10-99 club of Orange County in California, meets every third Thursday of the month. The club monitors channel 10. Coffee Breaks are held every Monday night at the Copper Penny, in Santa Ana. President of the 10-99 club is Kirk Kirkland; Vice President, Fred Curran; Treas., Delpha Dady; Sec'y, Joy Lefever.

Herb Hartley, KEJ6466, one of the editors of the Santa Barbara, California club paper, CB FLASHES, visited Whittier recently. He reported by air to the S9 A.P.R.E., R. M. Forester, KEJ5806, that all was well with the club, and that further news would be forth coming pronto.

A newly reporting club from Beaufort, South Carolina, THE SEA ISLANDER, was founded the 19th of February, 1963, by the members of the Citizens Communication Club of Beaufort, S. C., known as the "SEASLAND CB'ERS, for the entertainment and information of the club members and other interested persons. Thanks to E. B. Johnson, KDB0691.

COMING EVENT—The Central Indiana CB Club 11 Meter Jamboree at Hounds State Park, east of Anderson, Ind., on Route 232, July 21, 1963. Contact Ed Wood, 18B1251, P.O. Box 2155, Anderson, Ind.

Let's see more club news for this column, because as you know, WE BOAST THE MOST!!!!!! You just can't beat S9, so why not join us. GRRRRR-EAT

All club news should be directed to—S9, Club Editor, John F. Krejc, 40 Lanza Ave., Garfield, N. J. Why not add the CLUB EDITOR'S QSL CARD TO YOUR COLLECTION. 2W4586.

COMING EVENT—The Fort Henry CB Club of Wheeling, West Virginia will hold their "GIGANTIC CB Round-Up on Sunday, July 28th at the White Palace, Wheeling Park, Wheeling, West Va. Door prizes GALORE. Monitor channel 9.

COMING EVENT—The CB Club of Fresno, California will hold their First Annual CB Radio Jamboree, June 15th and 16th at Kearney Park.

The club project each year of the Black Warrior CB Club, Tuscaloosa, Ala., is participating in the radio pick-up for the Cerebral Palsy drive plus annual bar-b-que in July each year. President of the club is J. W. Jones, 6Q5235.

The 10-4 CB Radio club of Sylacauga, Ala., recently elected J. W. Smitherman, KDB0732, as president. The club meets every other Tuesday night alternating between Childerburg and Sylacauga.

The CEE BANDERS RADIO PHONE CLUB is going to provide communications for the Alabama Chapter, Sports Car Club of America at their races July 6-7th at Courtland, Ala. Send pictures, Pat.

COMING EVENT—The COOSA VALLEY CB club is holding its annual Jamboree Aug. 10 and 11, at Lake Rhea, Altalla, Ala.

The SUSQUE CB RADIO CLUB, P.O. Box 644, Williamsport, Pa., would like to exchange club papers with all. Chairman of the club is BOB OTT.

COMING EVENT—"Y" City Citizens Radio Assn. will hold their annual Jamboree June 23rd at Muskingum County Fairgrounds, RAIN or SHINE, Zanesville, Ohio.

For the benefit of summer travelers the Kern County Citizens Radio Assn., Bakersfield, Calif., will monitor channel 21 for any emergency conditions in the entire county. CALL 11W8877, which monitors 24 hours a day. Alternates 9 and 11.

COMING EVENT—The Zelenople Tri-County REACT Team of Zelenople, Pa., in conjunction with the Mars-Evans City Area REACT Team of Mars, Pa., will sponsor an action-packed, fun-filled afternoon for all CB'ers, June 23rd, at the Evans City Sportsman's Lodge, located approx. 2 miles north of Evans City on Route 528. Monitor channel 9 and 11.

On Monday, April 22, 1963 three severe tornados ripped through several small towns and farms causing considerable damage. The Illini Class D Radio Club had been on alert since early in the afternoon when their weather-watch group (not connected with the U.S. Weather Bureau or CD) spotted what appeared to be tornado weather. Soon afterwards they received a report from a CB'er near Decatur, Ill., that he had spotted a tornado touch the ground, and headed towards Champaign. The Illini club immediately notified local authorities of the sighting and of the threat to Champaign County. However, little was actually done with regards to the CB'ers warning and three tornados hit outlying communities with very little warning to residents. In addition, even after the tornados had hit and relief and first aid work was beginning, the club was not so much as requested to lend aid to the CD.

COMING EVENT—Giant eyeball QSO is planned for August 11th, at Santo Grove, Strawberry Hill, Norwalk, Conn.



WASHINGTON OUTLOOK

by EDWIN FREDERICK, 2W4580

Taking time out to finalize their new license fee program the FCC slacked off in their relentless clean-up of CB frequencies by reducing this month's actions to a mere 21. Feeling the FCC's wrath this month are:

4Q0384, Peter A. Lindquist, Morgantown, W. Va., license revoked for repeated failure to respond to official notices concerning alleged violation of 19.24(a)(1).

4W0152, Warren J. Currence, Elkins, W. Va., whose license was finally revoked after long months of back-and-forthing between the Commission and Currence. Currence was charged with using profane language and with working skip, his defense was based upon several facts, namely, 1) that the Commission violated the Secrecy of Communications Act by monitoring his transmissions without his permission, 2) that his voice was imitated over the air, 3) that the call sign issued to his station was in violation of international agreements, and 4) many other stations worked skip. His revocation became effective June 3.

6Q1466, Stanley D. Hash, Bristol, Tenn., revoked for repeated failure to respond to official notices concerning alleged violation of 19.33.

7Q0919, George Melvin Beane, Miami, Fla., given a notice to Show Cause why his license should not be revoked.

7W2383, Allison E. Newhall, Tampa, Fla., given a notice to show cause why his license should not be revoked for violation of Section 1.76.

11Q0250, Albert P. Maurer, Santa Ana, Calif., license revoked for repeated failure to respond to official notices concerning alleged violation of 19.33.

11Q2045, Bobby E. Edwards, Los Angeles, Calif., received a Show Cause notice for repeated failure to respond to official no-

tices concerning alleged violation of 19.33.

11Q5268, William P. Wilson, Santa Ana, Calif., received a Show Cause notice to repeated failure to respond to official FCC notices concerning alleged violation of 19.61(a).

18W5046, Robert C. Berry, Jeffersontown, Ky., license revoked for repeated failure to respond to official notices concerning alleged violation of 19.33.

19A7927, Marko Yerkovich, Detroit, Mich., received a Show Cause order for alleged violations of FCC regulations.

19Q6185, Rogers H. C. Davis, Sr., doing business as Woodward's Party Store, Lake Orion, Mich., license revoked for repeated failure to respond to official notices concerning alleged violation of 19.61(a).

KBA5393, Robert G. Maskell, Stoneham, Mass., directed to show cause why his license should not be revoked for repeated failure to respond to official notices concerning alleged violation of 19.61(a).

KDH4167, Andrew J. Talley, doing business as Florida Sod & Landscape Co., Miami, Fla., license revoked for repeated failure to official FCC notices concerning alleged violation of 19.61(a) and (c).

KED2105, Charles E. Slaughter, Austin, Texas, directed to show cause why his license should not be revoked for repeated failure to respond to official notices concerning alleged violation of Section 308(b) of the Communications Act and rules 1.76.

KEG0878, Don M. Carpenter, Amarillo, Texas, directed to show cause why his license should not be revoked.

KEJ1194, Donald K. Fisher, Sherman Oaks, Calif., directed to show cause why his license should not be revoked for repeatedly ignoring official FCC notices concerning alleged violation of 19.61(e).

KEJ2617, Hal Rountree, doing business as Property Maintenance & Repair Service, San Diego, Calif., asked to show cause why his license should not be revoked for repeated failure to respond to official FCC notices concerning alleged violation of 19.61(c) and 19.33.

KEJ4428, Dale E. Zacharias, Huntington Beach, Calif., license revoked for repeated failure to respond to FCC notices concerning violation of 19.33.

KEJ5209, David R. Coughlin, Whittier, Calif., asked to show cause why his license should not be revoked for repeated to answer official FCC notices concerning rule violation.

KEJ7142, Waymond T. Hendershot, San Pedro, Calif., directed to show cause why his license should not be revoked for repeated failure to respond to official FCC notices concerning alleged violation of 19.33.

KGE0146, Carl Swanson, doing business as Bob's Auto Repair, St. Paul, Minn., directed to show cause why his license should not be revoked for repeated failure to respond to official FCC notices concerning alleged violation of 19.61(a).



KBG4303 RIDES AGAIN

Continued from page 7

quire an examination to be checked over and graded, pay only \$4?

CB'ers have long devoted their time, experience and equipment selflessly in the interests of the public and the community. Commissioner Bartley, in his dissenting statement on the Docket, stated, "The Commission is charged with the responsibility of promoting maximum effectiveness in the use of wire and radio communication for service to the people of the United States and for the safety of their life and property. The assessment of fees would be a deterrent to effectuation of that purpose . . ." We agree.

Commissioner Ford, who also refused to go along with this Docket, suggested that the Commission send a comprehensive report on the subject of licensing fees to the Congress and let that body hassle it out and decide whether or not the fees should be imposed.

In view of the fact that the fee proposals of the past failed to get off the ground, it is doubtful that Congress would go along for the ride this trip. Reading over the new FCC Docket, we got the impression that the FCC itself is not actually *fully* convinced as to its

right to impose these fees. To quote from the Docket, "In Summary, the Commission *believes* it has the authority under Title V of the Independent Offices Appropriation Act of 1952 to adopt rules requiring the payment of fees for its licensing and regulatory activities." (Italics ours.) This is the same Act which was the basis of the Docket which failed in 1954; it's interesting to note that whatever made the fee proposal fail before seems now to have passed over.

We had all hoped that the Commission would be satisfied with the monies collected from its new "small forfeitures" bill, however this is apparently not so.

Personally, we don't believe that CB'ers would be against chipping-in an *equitable* amount towards the Commission's "cause" if it meant that there would be some more personnel at the now overworked and understaffed FCC. The \$8 fee is *not* equitable in relation to the other services, especially in view of the nature of the Citizens Radio Service. In addition, these fees will *not* go to the Commission for their own uses, they *must* be turned over to the Treasurer of the United States by the Commission.

We don't know if there is anything which can be done to reduce or eliminate these oppressive fees. Are you interested in trying? If you are, why not drop us a card or letter with your opinions? If we get enough of them we'll send them in a big CARE ("Citizens Anti Radio-Expense") package to the Commission.

In the meantime, watch for the birdie on January 1, 1964. If you have a license which you are thinking of modifying or renewing in early 1964, or if you are moving in 1964 and you already know the new address, you can save yourself some time and cash by sending in a new application before the end of the year. With the \$8 we've saved you, you can take a subscription to S9 and put the other \$3 towards that new dream rig.

SPECIAL GUEST EDITORIAL

by Charles Case, 18W6313
Waukesha County CB Club, Inc.
Oconomowoc, Wis.

ERNEST L. WALKER & THE A.C.B.A.

Mr. Walker received much publicity on his fight for CB'ers, but one very important item has been forgotten, Mr. Walker did continuously defy the law, even after being warned. He even made false statements in regard to the mobiles he was calling

which were parked in front of his house; actually he was using this as a disguise to call skip.

He bases his argument that it is unconstitutional for the FCC to tell him who he can talk to. If he sincerely feels this way, why use the mobile calling bit as a disguise? There are proper ways to protest laws we feel are unfair. If everyone broke a law every time they came across one that didn't seem right, just for the sake of proving a point, man, what a mess we would have.

The American Citizens Band Association was formed as an outgrowth of this Walker problem. They want every CB'er to send in a dollar for a year's membership. We need a national organization but look how many we've had so far. I am reminded of the NCRL in Chicago about a year ago; it looked real good, a big sensational show and then in came the money for a few months. Then, all of a sudden, letters were returned marked "Moved, left no forwarding address."

It seems the bad apple will always make you look twice at the good one, so before you rush your dollar in, make sure it's what you want. Personally, I would like to see a national organization tied in with the manufacturers' CEMA. Don't misunderstand me, the ACBA may be just what we need but let's make sure and not have another "Moved, left no forwarding address."

18W6313

Comments and opinions in the Guest Editorial are strictly those of its author and do not necessarily coincide with the opinions of S9 Magazine.

ANTENNAS

Continued from page 41

If the SWR ratio becomes progressively lower toward the high channel number it may well be an indication that the antenna has already been trimmed and is actually resonating at the high frequency end of the band or on the high frequency side of the band end. This indicates that the antenna may have been overtrimmed and needs some additional length. The effective length can sometimes be increased by crowding the turns nearer together near the end of the antenna. However, it is far better to proceed carefully so as not to overtrim this type of antenna.

TUNING THE SHORTY

The short antenna must be tuned very carefully. As mentioned in last month's column the short antenna has a high Q and therefore its bandwidth is much narrower. Thus it must be peaked very carefully. The job is critical because a very slight change in the length of a short antenna has a significant influence on its resonant frequency and impedance characteristics. In fact, it is recommended that its length be changed no more than $\frac{1}{8}$ th inch at a time as you attempt to peak the shorty on a given channel.

Usually the short antenna can be telescoped a limited amount. The antenna element is held firmly by a set screw. The screw is loosened and the antenna telescoped ever so slightly and then

locked into position again while a new measurement is made.

Usually the length over which it can be telescoped is adequate to bring the antenna into resonance for most installations. In some cases it is necessary to trim the end of the antenna. Again it is important that you do not trim too much because there is not much you can do about giving length to an overtrimmed short antenna.

Crater Lake supplies a small telescoping wire with their models. For a given installation this telescoping wire can be used for tune-up purposes. Its exact length can be measured and the regular antenna can then be cut very carefully to the same length.



ELECTRONICS 'N STUFF

Continued from page 31

wire! Since the RG-58/U is rated at say 150 watts its inherent loss will produce a specific (and safe) amount of heating. However, if the rating is grossly exceeded the excessive heating will melt the material insulating the two conductors and short the cable.

"The lower loss of RG-8/U is a definite advantage, but one which you have to pay for. If your installations requires an extremely long run of coaxial cable, it might be wise to use RG-8/U even though it may cost twice as much.

"Loss is expressed in the same decibels which we discussed several months ago and is usually given as db per hundred feet at a specific frequency. If you use 100 feet of cable which has a loss of 3 db per 100 feet at 30 megacycles, you will lose exactly one half of the power generated by your transmitter and cause a signal drop of one 'S' unit at the other guys' station. Knowing this, you can look up the type of cable you are using and closely estimate how much the cable is dropping your signal. Don't forget, though, that the loss specification varies from manufacturer to manufacturer.

"Here's another interesting fact about transmission lines—they actually slow down the radio frequency traveling through them. In free space a radio signal travels at the speed of light, or 186,000 miles per second. However, inside the cable our speeding friend, the electron, has his brakes applied. The exact reduction in speed is called the *propagation velocity* and for most types of coax the figure is 0.68. This means the r.f. is traveling only about two-thirds as fast, or about 126,000 miles per second.

"Propagation velocity is not just a laboratory curiosity but can be important to every CB'er. For example, we know that if we could see it, the wave length of a CB signal would be about 36 feet. Thus we say a quarter wave

antenna (such as a mobile whip) is about 9 foot long. But what if you purchased an antenna that was supposed to use a transmission line one half-wave length long? Would you go to the radio store and purchase 18 feet of coax? I hope not, because you would waste several feet.

"In actual practice one half-wave length of coax is its propagation velocity times the wave length in space. Thus the half-wave coax line for our imaginary antenna would be (.68 x 18 feet) or only 12 feet, 3 inches long. This is an important figure to remember, as we shall see.

"Another interesting fact about transmission lines is their *repeating characteristics*. If you measure a half-wave line you will find that it 'repeats' whatever is connected to its opposite end. If you short one end the r.f. energy entering the other end will 'see' a short. If you connect a perfectly matched antenna to one end, the r.f. will 'see' a perfect antenna at the other end. In plain English, what this means is that by using a half-wave transmission line, or multiples of a half-wave, your transmitter will tune and load just exactly the same as if the antenna were connected directly to the antenna terminal of the rig. You will still have the cable loss, however, but the use of half-wave line and multiples make the rig much easier to tune up.

"If you use a quarter-wave or multiples, the energy generated by the rig might see the perfectly matched antenna as high impedance rather than its normal low impedance. If your rig is designed to load into this higher impedance, fine, you have no problem, but if it has a limited tuning range—look out. You will not be able to transfer all the power generated by the rig, up to the antenna. This wasted energy will add to the loss of the cable and make your signal even weaker."

Sam concluded his discussion. "If you doubt this half-wave business, try using a 12 foot, 3 inch length of coax between your mobile rig and antenna. I'll bet it will tune much better and you may get more power output," Sam said. "By the way," he added, "I just received a new shipment of the new 'T' line. Supposed to be the lowest stuff on the market. "Who's first," he said, unlocking the cash register.

S9

ON THE COUNTERS

Continued from page 26

there's no built-in mobile supply; the basic unit operates only off the AC Mains. If you want mobile operation you can purchase the optional 6 or 12 VDC supply which mounts on the rear of the HE-90. Those who need

mobile operation pay for the service and those who need only a base rig don't have to pay for a circuit they don't need.

Another stripping is the plate current input meter which was standard on Lafayette's big rig. It has been replaced by the output meter and you now have to plug an external meter into a jack (provided) to measure plate current. Also, there is no carrying handle, you tuck it under your arm or you make your own.

For someone who needs just plain, reliable communications, without frills, the HE-90 packs all that's needed into an under-one-hundred-dollar package.

S9

TEST GEAR

Continued from page 44

Top of the group is: "101 Ways To Use Your VOM And VTVM" by Middleton, published by Howard Sams; this is primarily a beginner's reference. Short sections show the tricky uses for what is called the basic instrument. It covers everything, from the everyday usage of measuring voltage to using the VOM as a sensitive field strength meter. Nearly all the tips are illustrated, some show how to connect the equipment, others show the result which should be obtained. Without this reference you might never suspect the many uses of the VOM and VTVM.

We also recommend "How To Use Test Probes" by Chirardi and Middleton, published by Rider. This work is for the more technically advanced, but it belongs alongside "VOM and VTVM." Basically, probes are devices which convert instruments into other instruments. For example: you cannot measure RF voltage with a VOM—you would need an RF voltmeter. But, if you equip your VOM with an inexpensive RF probe (about \$3) you *can* measure RF voltage—get the picture? "Probes" details, in easy-to-read style, possibly every use for probes. And keep in mind that most probes you'll need can be built in a few minutes, and "Probes" shows the circuits.

While there are many other excellent references on test equipment, the ones given are probably the best value for the CB'er in that they are directly applicable to CB, rather than CB being a secondary interest.

S9

Continued from page 10

was the center of the particular channel and that this signal was being generated by precision equipment in the station. He made an adjustment in scale on the analyzing equipment and told me that each square on the grid now represented one kilocycle. At that moment another "blip" showed up to the right of the "marker blip", and slightly more than three kilocycles high in frequency. Mr. Johnson pointed a finger at the transgressor, and at my request, quickly attached the polaroid camera and snapped a picture of a CB station asking for a citation. In this instance, I believe the station was not identified, but how lucky can you be. For anyone in doubt as to his frequency, well—this could be a picture of your signal as recorded by the FCC monitor. While this equipment serves to indicate when a station *might* be off frequency, other extremely precise instruments are capable of being immediately coupled to the receiver for frequency measurement *to six decimal places*. In other words, your frequency can be measured so accurately that you could receive a notice identifying your signals as being, for example, 3.230596 kilocycles off frequency.

Needless to say, this is precision that stands up under any argument. Furthermore, the operator doesn't even have to read a meter. The exact frequency is indicated on a digital readout device, and then recorded by the operator. Mr. Weston remarked on the improvement in this area from the old days when an operator had to interpolate between known check points before he could approximate an unknown frequency.

Even further accuracy is possible, when required, as the station maintains a standard accurate to five part in ten billion. This is perhaps a thousand times greater accuracy than was possible even a few years ago.

Since most Citizen Banders, we're happy to say, are law abiding, and will never have an opportunity to see FCC Form 793, I asked Mr. Johnson for a copy. Herewith, for all to see, Form 793. May you never open your mail to find this tidy little greeting.

Since one of the major efforts of the Commission's monitoring program is devoted to rule enforcement, it was natural that our discussion should cover this point in detail. In particular, here are the points the monitors have in mind when listening on the Citizen Band.

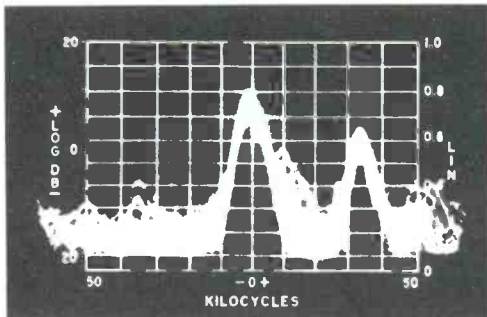

Unidentified CB station 3.2 kilocycles off frequency
(Official FCC photo)

- Failure to properly identify a station.
- Transmission of false call signs.
- Operation on a frequency not authorized.
- Failure to attenuate spurious emissions.
- Operation with power greater than authorized.
- Rendering a communication service not authorized.
- Operation with an unauthorized type of emission.
- Operation of equipment not authorized by the station license.
- Failure to respond to official communications from the Commission.

Amendments to the Communications Act provide for the assessment of forfeitures of \$100 each (up to a total of \$500) for the violations above, all of which are applicable to Citizen Band stations.

As a sidelight, your reporter was conducted to the second floor of the station. Here, in one room, was an exact reproduction of one of the monitoring positions found below. This facility is used for the instruction of personnel from other governments, and their training is carried on without interrupting the flow of business on the floor below. Armed with the finest of guidance and instruction, foreign visitors return to their own countries to establish similar monitoring installations.

Our conclusion: The FCC monitoring system is a safeguard for you and me. Call them "watchdogs" if you will, but contemplate, if you can, the state of conditions we would have throughout the radio spectrum if it weren't for these sentinels of the airwaves.

S9's sincere thanks to Messrs. George Turner, Irv Weston, and Hobart Johnson whose cordial reception and patience in answering all our questions made this special report possible.

S9



advertisers index

Browning Laboratories	8
e.c.i. electronics communications, inc.	Cover 3
Echo	56
Errol Engraving	35
Garth Printing	35
General Radiotelephone Corp.	Cover 4
Grove Electronics	38
Hallicrafters	5
Heath Co.	6
Hy-Gain Antenna Products	28, 29
International Crystal Mfg. Co.	Cover 2, 1
E. F. Johnson Co.	21
Euphonics	30
Lafayette Radio	11
Lew Bonn	25
Multi-Elmac Co.	38
Part 15 Identifier	37
Paulin Sales	14
Pearce-Simpson	30, 33
RCA	3
Raytronics	33
S9 Subscriptions	23
Seco	14
Shure Bros.	27
Sonar	27
Tram Electronics	26
Utica Communications	15
World Radio Labs	43

CB SHOP

Rates for CB SHOP are 10¢ per word for advertising which, in our opinion, is obviously of a non-commercial nature. A charge of 25¢ per word is made to all commercial advertisers or business organizations. A 5% discount is in effect for an advance insertion order for six consecutive months.

We do not bill for advertising in CB SHOP. Full remittance must accompany all orders and orders sent in otherwise will not be run or acknowledged.

Closing date is the 15th of the 2nd month preceding date of publication.

We reserve the right to reject advertising which we feel is not suitable.

Because the advertisers and equipment contained in the CB SHOP have not been investigated, the publishers of S9 cannot vouch for the merchandise or services listed therein.

IF YOU'RE LOOKING TO SAVE MONEY ON QSL'S LOOK ANYWHERE ON THIS PAGE—IF YOU WANT THE FINEST QSL'S AVAILABLE, SEND 15¢ TO THE MAD ART DIRECTOR/KBG7126/5009 Broadway, N. Y. C.

QSL CARDS, EYEBALL CARDS. The latest designs, colors, cardstock. **FREE SAMPLES. APRIL SIGN 56290** Van Dyke, Washington, Mich.

CBers—As described in feature article of March S9; Speech clipper-kit complete \$17.85. Also, our famous Dual Conversion easy-do adapter-kit, improves selectivity, increases sensitivity. For HE-15, A, B, 800, 910, B, etc. HE-20, A, B, C; Mark VII. 770, 1, 2. Messenger. GW-10, etc. All parts, schematic, pictorial complete; \$15.50, with tubes \$17.50, or \$5.00 deposit plus C.O.D. Order now! Free literature Dept. "6S" Bainbridge Radio Electronics, 2839 Briggs Ave., New York 58, N. Y., or your local dealer.

CB TRANSMITTERS \$6.00. Other bargains, send 10¢ for list. Vanguard, 190-48 99th Ave., Hollis 23, N. Y.

WALKIE-TALKIE RADIOS; CITIZEN BAND EQUIP.; INTERCOMS; RADIO-TV PARTS—FREE CATALOGUE—ALLEN ELECTRONICS, 4142A Main, Flushing 55, N. Y.

Heathkit owners, our preamps double reception! SK-3 Preselector kit fits GW-10, GW-11, \$8.99. SK-4 Preselector kit fits inside GW-12, \$8.99. Wired, \$11.99. Postpaid! **HOLSTROM ASSOCIATES, Box 8640-S, Sacramento 22, California.**

QSL CARDS, 100 for \$3.00. Samples 25¢. Red-bird Printers, Freedom, Indiana.

Looking? Shopping? Trading? Trying to save money? Write Bob Graham for special deals on new and reconditioned used gear. Cash or budget. Graham Radio, Dept. E, Reading, Massachusetts, Tel: 944-4000.

QUALITY QSL'S—New designs monthly, samples 10¢, Giant 25¢. **SAVORY, 172 Roosevelt, Weymouth, Mass.**

CB QSL CARDS—100 two color \$3.00 postpaid, samples 10¢. Rusprint, Box 7507, Kansas City 16, Missouri.

\$10 DOWN DELIVERS your CB equipment with 12 to 24 months to pay balance. This month's specials . . . RG8/U coaxial cable only 7¢ per foot (FOB New York) . . . also, any CB transmit or receive crystal, for any type of CB transceiver . . . \$2 each. Include 25¢ additional with order for postage and handling of crystal. House of Sound, 2119 Starling Avenue, New York 62, N. Y.

Free Samples CB QSL Cards \$2.50 per 100 in 3 colors. Garth, Jutland, New Jersey.

CB - HAM - QSL - EYEBALL CARDS. Samples and Price List 20¢. Dave, KHG9638, Box 41, Waynesville, Ohio.

QSL CARDS. Many sharp, cartoon designs . . . send for FREE brochure. F. B. Mathews Printing & Advertising, 1616 Rural Street, Rockford, Illinois.

MODULATION BOOSTER—It's new! It's terrific! As much as doubles your transmit and receive range with no violation of FCC power requirements. Compact, easy to install, with instructions. Net \$14.95. Dealers write too. ROKO Products, Inc., Box 3766, Baltimore 17, Maryland.

ANTENNA SWITCH—Operate one CB on two Antennas or two CB on one antenna. Attractive stainless steel, Takes PL-259 plugs. Net \$7.95. ROKO Products, Inc., Box 3766, Baltimore 17, Maryland.

CB QSLs. Glossy, two colors \$2.00 per 100, postpaid. Free sample. Hobby Print Shop, Umatilla, Fla.

CB QSL EyeBall Business cards printed, speedy service, best results, Samples 10¢. Sandy Press, 38 Ridge Avenue, Warrensburg, New York.

WANTED: CB TRANSCEIVERS. CASH WAITING. STAN KRZAK, PAWTUCKET, R. I.

CB REPAIRS—CALIBRATION, reasonable prices, FCC licensed technicians. ELECTRONIC SPECIALTIES, Box 13, East Patchogue, N. Y. Atlantic 6-9467.

CREATIVE CBL CARDS—Free, new catalog and samples. Personal attention given. Wilkins Creative Printing, P.O. Box 1064-9, Atascadero, California.

CB-QSL's over 100 designs, samples 10¢. Roger KOAAB, 961 Arcade, St. Paul 6, Minn.

FOR SALE—General MC-5 CB Unit, Complete—22 Transmit & 3 Receive Xtals. 2 power cords—Mobile Mounting. \$225.00—Postage Pre-paid in USA. Mr. Stanley Schneider, KBG6254, 754 Bronx River Road, Yonkers, New York.

CB QSL Cards, New Kute, Klever, Komical designs. Some low as \$1.80 per 100. Brilliant colors including silver and gold. Samples 10¢. M. Hellwig, Box 425, Lake Wales, Florida.

CALL SIGNS—Attractive CB call signs are permanently engraved white letters on fade-resistant black formica; adhesive-backed for easy installation on base or mobile units. Call only— $\frac{3}{8}$ x $2\frac{1}{4}$ "—\$1.45; Call plus "unit" or "Mobile" number— $15/16$ x $5\frac{5}{8}$ "—\$1.95; Desk model, plastic base, call only— $1\frac{1}{2}$ x $5\frac{5}{8}$ "—\$2.95; Door or wall sign, adhesive-backed or drilled— $1\frac{1}{2}$ x $5\frac{5}{8}$ "—\$2.95. Shipped postpaid. Satisfaction guaranteed. Full refund within 10 days. Northwest Engravings, Box 1020-S, Corvallis, Oregon.

Gun Collector will accept Luger and P38 pistols as part payment for excellent used Radio Gear. P.O. Box 22, Clarendon Hills, Ill.

SWAP QSL's?—SEND Your card to Jim Cross KCF0823, 755 S. Poto, Hagertstown, Md.

NOW—cards of distinction for discriminating CBers. Your photo on cards from snapshots or send us your ideas and designs for custom work by professional artist, samples 25¢. Dick McGee, 1444 Home Street, Jacksonville 7, Fla.

STONE SIGNALS. Legal. New "High-Level" pulse. Adaptable all units. \$4.95 each, complete. Ideal Enterprises, Box E, Wessington, S. D.

IMPROVE GW-10 PERFORMANCE! — Better transmission, reception! Reduce mobile noise! Instructions \$1.00, postpaid. FRANKEL, Box A-143, Wantagh, New York.

CB QSL card. Samples 10¢—MALGO PRESS, Box 375—Toledo 1, Ohio.

CB, QSL, SWL Cards that are different. Quality Card Stock. Samples 10¢ Home Print, 2416 Elmo, Hamilton, Ohio.

GLOSSY 3-color QSL cards 100 — \$4.50. Free samples. Rutgers Vari-Typing Service, 7 Fairfield Road, Somerset, New Jersey.

CB-HAM-QSL-EYEBALL Cards. Samples & Price List 20¢. Dave—KHG9638, Box 291, Waynesville, Ohio.

CB QSL Cards 2-Color Glossy, 100 for \$2.50. Samples Dime. Rambsbottom Printing. Box 237S, Kirksville, Mo.

New "Audio-Aid-All" Clipper-Filter kit, fits any transceiver, boosts modulation, aids reception, \$10.99 complete. 29" Hy-Gain Omni-Topper, \$10.97. DB-2 BC/CB Antenna Coupler-Duplexer kit, \$4.99. New, revolutionary Noisejector, NJ-7, \$4.49. Postpaid! Free kit list. HOLSTROM ASSOCIATES, Box 8640-S, Sacramento 22, California.

QSL's—LOW COST, 100 for \$1.75 postpaid. Sample for stamped envelope. Reed Advertising, 546 Pond Run Road, Raceland, Ky.

CLUB COURTESY CARDS, 1000 for only \$4.50 postpaid. Send copy to Reed Advertising, 546 Pond Run Road, Raceland, Ky.

CB QSL CARD samples 25¢. Sakkers, W8DED S9 Samples, Box 218, Holland, Michigan.



We'll Stand On Our Heads to give you the best deal possible on your CB gear!

COURIER 1-M



- **Tops in C. B. Transceivers**
- TRIPLE CONVERSION
- 12 Channel Transmit
- R.F. "S" meter (lighted)
- Lighted 23 channel tunable
- R.F. Gain Control
- Proven Quality

only **\$229 50**

or **\$19 50** down and **\$17 58** per month for 12 months

All Couriers Fully Guaranteed

antenna specialists

M-81 MAGNUM base antenna

FREE with every Courier 1-M

or only **\$24⁸⁷** prepaid to your door
Only at ECHO

ECI LINEAR AMPLIFIER

Boosts transmitting power. Illegal on 11 meters in U.S.
\$13.30 per month (12 mos.)

\$14 50 DOWN

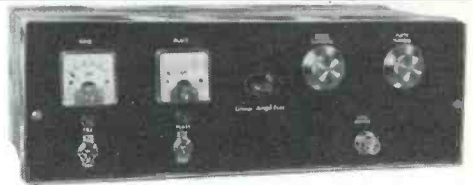

\$159.50

ECI FLEET COURIER

Rugged new 5-channel compact. Powerful, quiet—ideal for mobile or base.

Just **\$159.50** with **FREE** Magnum or **\$14 50** DOWN
\$13.30 per month (12 mos.) or **\$7.25** per month (24 mos.)

- Down payment for \$19.50 enclosed. Rush forms on Courier 1-M for 12 months
- \$229.50 enclosed. Ship Courier 1-M
- \$14.50 down payment enclosed for Fleet Courier. Send forms on 12 mos.
- Here's \$159.50. Send Fleet Courier
- \$14.50 down payment enclosed for Liner Amplifier. Send forms for 12 mos.
- Ship Linear pronto! \$159.95 enclosed.
- \$24.87 Enclosed. Ship Magnum M-81 today.

ECHO

COMMUNICATIONS INC.

Box 223 Cedarburg, Wisconsin
Phone Drake 7-3800—Ask for Sandy

NAME

ADDRESS

CITY and STATE



COURIER 1-M

NOW!

QUIETEST

MOST POWERFUL

MOBILE

C.B. UNIT!

HEAR IT TO BELIEVE IT!

Write for Free Brochure \$229.50 list, slightly higher west of Rockies.

 **e.c.i. electronics communications, inc.** 325 no. macquesten pkwy, mt. vernon, n. y.

General MC5 Sidebander

the measure of quality for all citizens band transceivers



The World's most advanced 11 Meter two-way radio

FREE—
Write for schematic
and complete
technical manual

3.25 watts minimum output. • Sideband receiver adapter[®] for single and double sideband reception. • New Zener Diode shunt noise-clamp and series gated limiter circuit for highest noise limiting ever achieved. • New ultra-low drift oscillators for unsurpassed stability. • New Hi Level Tone-Signal. • Illuminated "S" Meter. • 6V, 12V, 115V operation. • 15 watt construction. • Net Price including microphone and crystal... \$199.95. • Sideband receiver adapter optional \$19.95 + inst. Optional accessories available. 6 Volt or 12 Volt cord, each \$4.95. Crystal T or R, each \$2.95. 90 day warranty. F.O.B. Burbank, California.

Under present rules part 19.32 the FCC does not provide for more than (5) watt input in the Citizens Radio Service (26.965-27.225 MC Band)



General's SIDEBAND TRANSMITTER —Available February 15, 1963!

A new concept in C.B. Communications. A Sideband Transmission Adapter and AM Linear Amplifier all in one package...and best of all True Electronic Switching—Just plug it Into the antenna. This unit may also be used on the 10 meter band at 50 Watts P.E.P. Sideband and 25 Watts P.E.P. AM with only 3 watts of drive.

This Dual Function... Sideband and AM Linear Amplifier for 10 and 11 meters is only \$99.95 Net. F.O.B. Burbank, California.

GENERAL RADIOTELEPHONE COMPANY

3501 West Burbank Boulevard, Burbank, California



300 West 43rd Street
New York 36, N.Y.

Controlled Circulation Postage Paid at New York, N. Y.

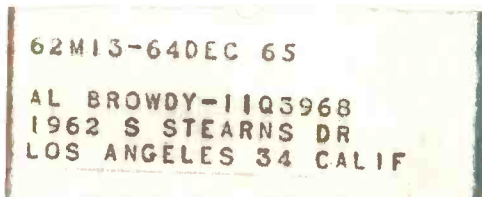

POSTMASTER: SEND FORM 3579 TO: SR, 300 WEST 43rd STREET, NEW YORK 36, N. Y.